

IC0520 Series

Din-rail Fanless Embedded System

User's Manual



USER'S MANUAL

www.axiomtek.com

Disclaimers

This manual has been carefully checked and believed to contain accurate information. Axiomtek Co., Ltd. assumes no responsibility for any infringements of patents or any third party's rights, and any liability arising from such use.

Axiomtek does not warrant or assume any legal liability or responsibility for the accuracy, completeness or usefulness of any information in this document. Axiomtek does not make any commitment to update the information in this manual.

Axiomtek reserves the right to change or revise this document and/or product at any time without notice.

No part of this document may be reproduced, stored in a retrieval system, or transmitted, in any form or by any means, electronic, mechanical, photocopying, recording, or otherwise, without the prior written permission of Axiomtek Co., Ltd.

©Copyright 2024 Axiomtek Co., Ltd.

All Rights Reserved

May 2024, Version A1

Printed in Taiwan

Safety Precautions

Before getting started, please read the following important safety precautions.

1. The ICO520 does not come equipped with an operating system. An operating system must be loaded first before installing any software into the computer.
 2. Be sure to ground yourself to prevent static charge when installing the internal components. Use a grounding wrist strap and place all electronic components in any static-shielded devices. Most electronic components are sensitive to static electrical charge.
 3. Disconnect the power cord from the ICO520 before making any installation. Be sure both the system and the external devices are turned OFF. Sudden surge of power could ruin sensitive components. Make sure the ICO520 is properly grounded.
 4. Make sure the voltage of the power source is correct before connecting the equipment to the power outlet.
 5. Turn OFF the system power before cleaning. Clean the system using a cloth only. Do not spray any liquid cleaner directly onto the screen.
 6. Do not leave this equipment in an uncontrolled environment where the storage temperature is below -45°C or above 85°C. It may damage the equipment.
 7. Do not open the system's back cover. If opening the cover for maintenance is a must, only a trained technician is allowed to do so. Integrated circuits on computer boards are sensitive to static electricity. To avoid damaging chips from electrostatic discharge, observe the following precautions:
 - Before handling a board or integrated circuit, touch an unpainted portion of the system unit chassis for a few seconds. This will help to discharge any static electricity on your body.
 - When handling boards and components, wear a grounding wrist strap, available from most electronic component stores.
 8. Warning:

Replacing the battery with an incorrect type can result in an explosion risk. Dispose of used batteries according to the instructions.
 9. Caution:

Do not touch the surface of the unit, which can become quite hot during operation.

Restricted access area: The equipment should only be installed in a restricted access area.
 10. 10. This product is intended to be supplied by a Listed Power Adapter or DC power source, output meets SELV, rated 12-24Vdc, minimum 4.01A -1.01A, Tma = 50 degree C, and the altitude of operation = 2000m.
- If you need further assistance while purchasing the power source, please contact the manufacturer for further information.

Classification

1. Degree of protection against electric shock: not classified
2. Degree of protection against the ingress of water: IP20
3. Equipment not suitable for use in the presence of a flammable anesthetic mixture with air or with oxygen or nitrous oxide.
4. Mode of operation: Continuous
5. Type of protection against electric shock: Class I equipment

General Cleaning Tips

You may need the following precautions before you begin to clean the computer. When you clean any single part or component for the computer, please read and understand the details below fully.

When you need to clean the device, please rub it with a piece of dry cloth.

1. Be cautious of the tiny removable components when you use a vacuum cleaner to absorb the dirt on the floor.
2. Turn the system off before you start to clean up the component or computer.
3. Never drop the components inside the computer or get circuit board damp or wet.
4. Be cautious of all kinds of cleaning solvents or chemicals when you use them for the sake of cleaning. Some individuals may be allergic to the ingredients.
5. Try not to put any food, drink or cigarette around the computer.

Cleaning Tools

Although many companies have created products to help improve the process of cleaning your computer and peripherals users can also use household items to clean their computers and peripherals. Below is a listing of items you may need or want to use while cleaning your computer or computer peripherals.

Keep in mind that some components in your computer may only be cleaned using a product designed for cleaning components of the same types. Please read the instructions that come with a cleaning product to avoid misuse.

- Cloth: A piece of cloth is the best tool to use when rubbing up a component. Although paper towels or tissues can be used on most hardware as well, we still recommend you to rub it with a piece of cloth.
- Water or rubbing alcohol: You may moisten a piece of cloth a bit with some water or rubbing alcohol and rub it on the computer. Unknown solvents may be harmful to the plastics parts.
- Vacuum cleaner: Vacuuming the dust, dirt, hair, cigarette particles, and other particles out of a computer can be one of the best methods of cleaning a computer. Over time these items can restrict the airflow in a computer and cause circuitry to corrode.
- Cotton swabs: Cotton swabs moistened with rubbing alcohol or water are excellent tools for wiping hard to reach areas in your keyboard, mouse, and other locations.
- Foam swabs: Whenever possible it is better to use lint free swabs such as foam swabs.



Note: *We strongly recommended that you should shut down the system before you start to clean any single components.*

Please follow the steps below:

1. Close all application programs;
2. Close operating software;
3. Turn off power;
4. Remove all device;
5. Pull out power cable.

Scrap Computer Recycling

Please inform the nearest Axiomtek distributor as soon as possible for suitable solutions in case computers require maintenance or repair; or for recycling in case computers are out of order or no longer in use.

Trademarks Acknowledgments

Axiomtek is a trademark of Axiomtek Co., Ltd. IBM, PC/AT, PS/2, VGA are trademarks of International Business Machines Corporation.

Intel[®] Core[™] and Celeron[®] processors are registered trademarks of Intel Corporation. MS-DOS, Microsoft C and QuickBASIC are trademarks of Microsoft Corporation.

VIA is a trademark of VIA Technologies, Inc.

SST is a trademark of Silicon Storage Technology, Inc.

UMC is a trademark of United Microelectronics Corporation. Other brand names and trademarks are the properties and registered brands of their respective owners.

Table of Contents

Disclaimers.....	ii
Safety Precautions.....	iii
Classification.....	iv
General Cleaning Tips	iv
Scrap Computer Recycling.....	vi
SECTION 1 INTRODUCTION.....	1
1.1 General Description	1
1.2 System Specifications	3
1.2.1 CPU	3
1.2.2 BIOS	3
1.2.3 System Memory	3
1.2.4 Display	3
1.2.5 Ethernet Ports	4
1.2.6 Storages.....	4
1.2.7 Wireless	5
1.2.8 COM Port: (optional, only for Fully Type)	7
1.2.9 DIO: (optional, only for Fully Type).....	8
1.2.10 LED.....	9
1.2.11 Power& Reset Button.....	10
1.2.12 Power	10
1.2.13 WatchDog Timer (WDT)	10
1.2.14 Restore BIOS Optimal Defaults (CLEAR CMOS)	10
1.2.15 Operation Temperature.....	10
1.2.16 Storage Temperature	10
1.2.17 Humidity	10
1.2.18 Weight.....	10
1.2.19 Dimensions	11
1.2.20 System I/O Outlets.....	11
1.2.21 Check list.....	11
1.2.22 System Power consumption	12
1.2.23 System Block diagram	13
1.2.24 Placement.....	14
1.2.25 Connectors.....	16
1.3 Dimensions.....	17
1.4 I/O Outlets.....	19
SECTION 2 HARDWARE INSTALLATION.....	21
2.1 Installing the Memory & Wireless Module	21
2.2 Installing the Hard Disk \ NVMe Drive	28
2.3 Installing the DIN-rail Mounting Kit.....	33
CHAPTER 3 AMI UEFI BIOS UTILITY.....	35
3.1 Entering Setup	35
3.2 The Main Menu	36
3.3 Advanced Features	37
3.4 Chipset Feature	56
3.5 Security.....	57
3.6 Boot Type	65
3.7 Save & Exit	67
APPENDIX A WATCHDOG TIMER	69

About Watchdog Timer	69
How to Use Watchdog Timer	69
APPENDIX B POWER BUTTON SETTING FOR WINDOWS.....	71
APPENDIX C DIGITAL I/O	75

SECTION 1

INTRODUCTION

This chapter contains general information and detailed specifications of the ICO520. The Chapter 1 includes the following sections:

- General Description
- System Specification
- Dimensions
- I/O Outlets

1.1 General Description

The fanless embedded system ICO520 is an industrial-grade gateway with a robust hardware design, an ideal solution for communications control and protocol converter applications in harsh environments. Designed for operation in strict conditions, the ICO520 adopts a low power consumption Intel Alder Lake-P i7/ i5/ i3/ Celeron processor, supporting industrial operating temperature range from -40°C to +50°C. The ICO520 offers a wide selection of I/O functions, including 4 x USB, 2 x HDMI, 4 x 2.5GbE LAN, 16-bit isolated DIO and 4 x isolated COM design. Its size makes it suitable for DIN rail or wall mount, allowing users to easily put it into a control cabinet. Compatible with Windows®10/11 and Linux, the ICO520 provides programmers with a friendly environment for developing application software at a lower cost. There two kinds of categories for ICO520, one is Fully type and the other one is Simplified type. The main difference between Fully type and Simplified type is I/O extensible capabilities.



Fully Type



Simplified Type

The ICO520 adopts an advanced cooling system and supports the 2.5" SATA drive, mSATA and M.2 NVMe (2242, 2280), making it a perfect field control & edge computer solution for the following markets:

- Utility industries (water; energy; chemical plant; mining...)
- Public transportation industries (traffic/highway control; train wayside control...)
- Homeland security (weather monitoring/alarm system...)

- **Features(Fully Type)**

- Fanless design
- Wide temperature operation:
 - with i7-1265UE and i5-1245UE: -40°C ~ +50°C
 - with i3-1215UE and Celeron 7305E: -40°C ~ +60°C
- Supports 4 RJ-45 2.5Gb Ethernet ports
- Supports dual display, 2 HDMI ports
- 4 USB3.1 ports
- 6 LED indicators (power, SSD, 4 x programmable)
- I/O window for mini card expansion
 - 1 x M.2 Key B 3050/3052 slot: PCIe/USB (for 5G/Wi-Fi)
 - 1 x Full-size Rev.1.2 PCI Express Mini Card slot: PCIe/USB (for LTE/Wi-Fi)
 - 1 x Full-size Rev.1.2 PCI Express Mini Card slot: USB/SATA (for Wi-Fi/mSATA)
 - 3 x SIM slot (1 for M.2; 2 for full-size PCI Express Mini Card)
 - 1 x M.2 (PCIe Gen4 x4): NVMe (2242/2280) (optional, only for Fully Type)
- Supports one 2.5" SATA SSD and one full-size mSATA
- Module for I/O expansion:
 - 8-pin isolated Digital Input ports (source type)
 - 8-pin isolated Digital Output ports (sink type)
 - 4 isolated COM ports with 4-wire and phoniex type, supporting RS-232/422/485
 - one M.2 (PCIe Gen2x4) NVMe (2242, 2280)
- Wide range 12 ~ 24V DC-in with terminal block, supporting OVP, UVP, OCP, RPP
- Din-Rail mounting (default) and wall mounting (optional)
- Passed CE, FCC and UKCA testing

- **Features(Simplified Type)**

- Fanless design
- Wide temperature operation:
 - with i7-1265UE and i5-1245UE: -40°C ~ +50°C
 - with i3-1215UE and Celeron 7305E: -40°C ~ +60°C
- Supports 4 RJ-45 2.5Gb Ethernet ports
- Supports dual display, 2 HDMI ports
- 4 USB3.1 ports
- 6 LED indicators (power, SSD, 4 x programmable)
- I/O window for mini card expansion
 - 1 x M.2 Key B 3050/3052 slot: PCIe/USB (for 5G/Wi-Fi)
 - 1 x Full-size Rev.1.2 PCI Express Mini Card slot: PCIe/USB (for LTE/Wi-Fi)
 - 1 x Full-size Rev.1.2 PCI Express Mini Card slot: USB/SATA (for Wi-Fi/mSATA)
 - 3 x SIM slot (1 for M.2; 2 for full-size PCI Express Mini Card)
- Supports one 2.5" SATA SSD and one full-size mSATA
- Wide range 12 ~ 24V DC-in with terminal block, supporting OVP, UVP, OCP, RPP
- Din-Rail mounting (default) and wall mounting (optional)
- Passed CE, FCC and UKCA testing

- **Embedded O.S. Supported**
 - Windows[®] 10/11 64bit
 - Linux 64bit

1.2 System Specifications

1.2.1 CPU

- Onboard Intel[®] Core™ i7-1265UE processor (1.7GHz, 10-core)
- Onboard Intel[®] Core™ i5-1245UE processor (1.5GHz, 10-core)
- Onboard Intel[®] Core™ i3-1215UE processor (1.2GHz, 6-core)
- Onboard Intel[®] Celeron-7305E processor (1GHz, 5-core)

1.2.2 BIOS

- AMI (American Megatrends Inc.) UEFI (Unified Extensible Firmware Interface) BIOS

1.2.3 System Memory

- 1 x DDR4-3200 SO-DIMM Socket, up to 32GB

1.2.4 Display

- 2 x HDMI(up to 1920 x 1080 @60Hz)

Pin	Signal	Pin	Signal
1	HDMI_Data2+	11	Ground
2	Ground	12	HDMI_Clock -
3	HDMI_Data2-	13	No connected
4	HDMI_Data1+	14	No connected
5	Ground	15	HDMI_SCL
6	HDMI_Data1-	16	HDMI_SDA
7	HDMI_Data 0+	17	Ground
8	Ground	18	+5V power
9	HDMI_Data 0-	19	HDMI_HTPLG
10	HDMI_Clock+		

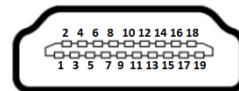

1.2.5 Ethernet Ports

- LAN Chip: Intel Ethernet Controller I226IT.
- The board has dual RJ-45 connectors, supporting 10/100/1000/2500 Base-T with 1.5KV magnetic isolated protection.

Pin	Description	10/100Base-T	1000/2500Base-T
1	Transmit Data+ or Bidirectional	TX+	BI_DA+
2	Transmit Data- or Bidirectional	TX-	BI_DA-
3	Receive Data+ or Bidirectional	RX+	BI_DB+
4	Not Connected or Bidirectional	N.C.	BI_DC+
5	Not Connected or Bidirectional	N.C.	BI_DC-
6	Receive Data- or Bidirectional	RX-	BI_DB-
7	Not Connected or Bidirectional	N.C.	BI_DD+
8	Not Connected or Bidirectional	N.C.	BI_DD-
A	Speed LED	OFF	Green / Orange
B	Activity Link LED	OFF: No Link Blinking: Data activity detected (Yellow)	

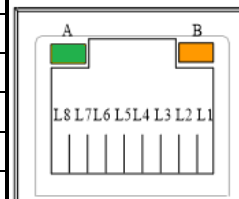

1.2.6 Storages

- 1 x Internal 2.5" SATA Drive(CN6)
- 1 x mSATA Drive(share with one mini PCIe slot) (CN11)
- 1x NVMe M.2 2240/2280 PCIe Gen2x4 (optional on fully type) (SCN1)

1.2.7 Wireless

- 1 x Full-size Rev.1.2 PCI Express Mini Card slot: PCIe/USB (for LTE/Wi-Fi) (Socket CN10).
- 1 x Full-size Rev.1.2 PCI Express Mini Card slot: USB/SATA (for Wi-Fi/mSATA) (Socket CN11).

Full-size Mini Card

Pin	Signal	Pin	Signal
1	WAKE#	2	+3.3VSB
3	N.C.	4	GND
5	N.C.	6	+1.5V
7	CLKREQ#	8	SIM_PWR / N.C.
9	GND	10	SIM_DATA / N.C.
11	N.C.	12	SIM_CLK / N.C.
13	N.C.	14	SIM_REST / N.C.
15	GND	16	SIM_VPP / N.C.
17	N.C.	18	GND
19	N.C.	20	+3.3VSB
21	GND	22	PERST#
23	PE_RXP	24	+3.3VSB
25	PE_RXN	26	GND
27	GND	28	+1.5V
29	GND	30	SMB_CLK
31	PE_TXN	32	SMB_DATA
33	PE_TXP	34	GND
35	GND	36	USB_DN
37	GND	38	USB_DP
39	+3.3VSB	40	GND
41	+3.3VSB	42	LED_WWAN#
43	GND	44	LED_WLAN#
45	N.C.	46	LED_WPAN#
47	N.C.	48	+1.5V
49	N.C.	50	GND
51	N.C.	52	+3.3VSB
53	N.C.	54	N.C.
55	N.C.	56	N.C.

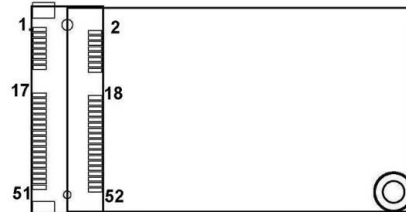

- 1x M.2 Key B 3050/3052 slot: PCIe/USB (for 5G/Wi-Fi)
(Socket CN1)

M.2 Key B

Pin	Signal	Pin	Signal
1	N.C.	2	+3.3VSB
3	GND	4	+3.3VSB
5	GND	6	+1.8VSB
7	USB2_DP	8	+1.8VSB
9	USB2_DN	10	N.C.
11	GND	12	
		20	+1.8VSB
21	N.C.	22	N.C.
23	N.C.	24	N.C.
25	N.C.	26	+1.8VSB
27	GND	28	N.C.
29	USB3_RX_DN	30	SIM_REST
31	USB3_RX_DP	32	SIM_CLK
33	GND	34	SIM_DATA
35	USB3_TX_DN	36	SIM_PWR
37	USB3_TX_DP	38	DEVS_LP
39	GND	40	N.C.
41	PCIE_RX_DN	42	N.C.
43	PCIE_RX_DP	44	N.C.
45	GND	46	N.C.
47	PCIE_TX_DN	48	N.C.
49	PCIE_TX_DP	50	PERST#
51	GND	52	CLKREQ#
53	CLKOUT_DN	54	WAKE#
55	CLKOUT_DP	56	N.C.
57	GND	58	N.C.
59	N.C.	60	N.C.
61	N.C.	62	N.C.
63	N.C.	64	N.C.
65	N.C.	66	+1.8VSB
67	PLTRST	68	SUSULK
69	GND	70	+3.3VSB
71	GND	72	+3.3VSB
73	GND	74	+3.3VSB
75	GND		



- 3 x SIM slot (1 for M.2 on CN4; 2 for full-size PCI Express Mini Card on CN9 and CN13)
- 5 x Antenna holes

Pin	Signal
1	SIM_PWR
2	SIM_RESET
3	SIM_CLK
5	GND
6	SIM_VPP
7	SIM_DATA

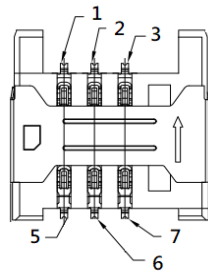

1.2.8 COM Port: (optional, only for Fully Type)

- 4 ports terminal block support RS-232/422/485 which can be selected by BIOS with isolation 2KV protection.
- Supports Auto Flow Control in RS485 mode.

COM1~2

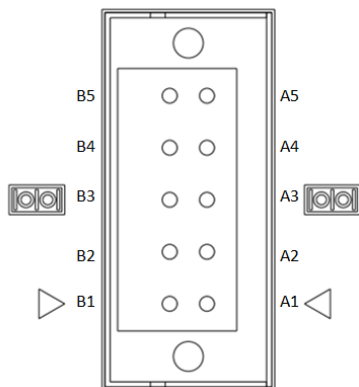

Pin	RS232	RS422	RS485
A1	GND	GND	GND
A2	RTS	RX-	N.C
A3	TX	RX+	N.C
A4	CTS	TX-	D-
A5	RX	TX+	D+
B1	GND	GND	GND
B2	RTS	RX-	N.C
B3	TX	RX+	N.C
B4	CTS	TX-	D-
B5	RX	TX+	D+

COM3~4

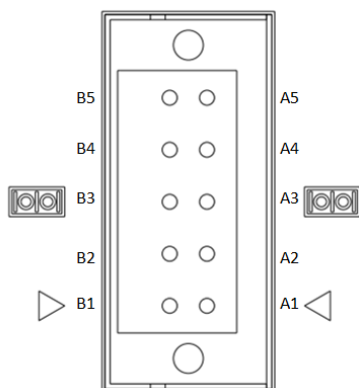

Pin	RS232	RS422	RS485
A1	GND	GND	GND
A2	RTS	RX-	N.C
A3	TX	RX+	N.C
A4	CTS	TX-	D-
A5	RX	TX+	D+
B1	GND	GND	GND
B2	RTS	RX-	N.C
B3	TX	RX+	N.C
B4	CTS	TX-	D-
B5	RX	TX+	D+

1.2.9 DIO: (optional, only for Fully Type)

- 8bit DI and 8bit DO with 2KV optical isolation

Digital Input	
Input Channels	8 source type
Input Voltage	0 to 30VDC Input
Digital Input Levels for Dry Contacts	Logic level 0: Close to GND. Logic level 1: Open
Digital Input Levels for Wet Contacts	Logic level 0: +10V to +24V (DI To XIN_COM-). Logic level 1: +3V max.
<ul style="list-style-type: none"> • When external device inputs HIGH pulse, DI will be mapping to logic level 0 (LOW). It needs to do inversing in software to get HIGH status. 	
Digital Output	
Output Channels	8 sink type
Output Current	Max. 200 mA per channel, current sink type
External voltage	10 to 30VDC, open collector to 30V

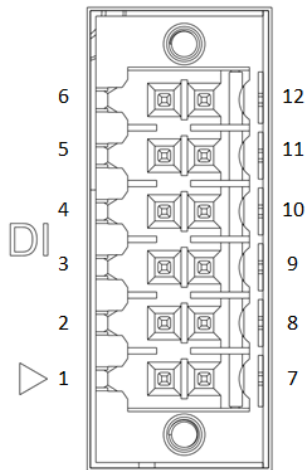

Pin	DI
1	External PWR
2	DI 8
3	DI 9
4	DI 10
5	DI 11
6	DIO_GND
7	External PWR
8	DI 12
9	DI 13
10	DI 14
11	DI 15
12	DIO_GND

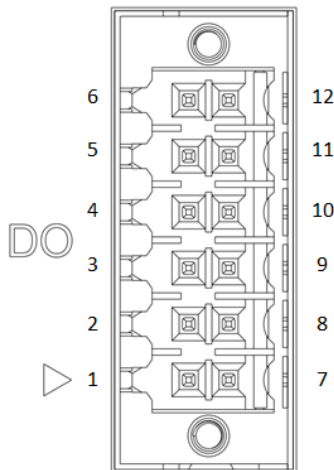

Pin	DO
1	COM+
2	DO 0
3	DO 1
4	DO 2
5	DO 3
6	COM-
7	COM+
8	DO 4
9	DO 5
10	DO 6
11	DO 7
12	COM-

- When the external device inputs a high-level pulse, DI will correspond to logic low-level. If the controller reads the same logic as the external state, it needs to be inverted in software to get the high state.

1.2.10 LED

LED Indicator	Description
PWR/ Green	Power on
SSD/ Yellow	SSD activity
P1/ Green	Programmable
P2/ Green	Programmable
P3/ Green	Programmable
P4/ Green	Programmable

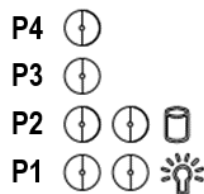

1.2.11 Power& Reset Button

- AT auto power on
- Reset Button.

Pin	Description
1	Reset Button



Note: Refer to APPENDIX B for instructions on Power button settings for Windows.

1.2.12 Power

- Wide-range 12 - 48V DC power input with terminal block.
OVP, UVP, OCP, RPP.

Pin	Signal
1	VIN +
2	N/A
3	VIN -

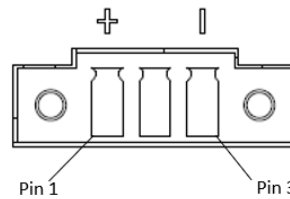

1.2.13 WatchDog Timer (WDT)

- 1~255 seconds or minutes; up to 255 levels.

1.2.14 Restore BIOS Optimal Defaults (CLEAR CMOS)

- Push the CMOS Button on the mother board for a few seconds. Doing this procedure can restore BIOS optimal defaults.

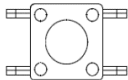

1.2.15 Operation Temperature

- System with i7-1265UE or i5-1245UE supports -40°C to +50°C (-40°F to +122°F)
- System with i3-1215UE or 7305E supports -40°C to +60°C (-40°F to +140°F)

1.2.16 Storage Temperature

- -40.0°C ~ +85.0°C

1.2.17 Humidity

- 10% ~ 95% (non-condensation)

1.2.18 Weight

- Fully Type: 1.75 kg (3.86 lb)
- Simplified Type: 1.65 kg (3.84 lb)

1.2.19 Dimensions

- 82mm(3.42") (W) x135mm(5.31") (D) x155mm(6.1") (H)

1.2.20 System I/O Outlets

- Two HDMI connector display.
- Four 10/100/1000/2500 base-T RJ-45 connectors with 1.5KV magnetic isolated protection.
- Four USB 3.1 connectors.
- Two 2x6-pin terminal block connectors for DIO.
- Four Terminal Block connector for COM.
- One DC power input with 3-pin terminal block.
- Five antenna holes.
- Three external SIM slots.

1.2.21 Check list

Fully Type

- ICO520 System Unit x 1
- Din-rail Kit x 1
- Terminal block(3x1pin) of Power x1
- Terminal block(6x2pin) of DIO x2
- Terminal block(2x5pin) of COM x 2
- DDR Thermal Pad x 1 and Breaket for DDR Thermal Pad x 1
- M.2 KeyB Thermal Pad x 1 and Breaket for M.2 KeyB Thermal Pad x 1
- SSD Tray x 1
- Screws for 2.5" SATA SSD x 4
- Screws(M3*6L) for 2.5" SATA SSD Tray x 4
- Screws(M2*5L) for Mini Card x 2 and screws(M3*3L) for M.2 x 1
- Breaket for HDMI x 2

Simplified Type

- ICO520 System Unit x 1
- Din-rail Kit x 1
- Terminal block(3x1pin) of Power x1
- DDR Thermal Pad x 1 and Breaket for DDR Thermal Pad x 1
- M.2 KeyB Thermal Pad x 1 and Breaket for M.2 KeyB Thermal Pad x 1
- SSD Tray x 1
- Screws for 2.5" SATA SSD x 4
- Screws(M3*6L) for 2.5" SATA SSD Tray x
- Screws(M2*5L) for Mini Card x 2 and screws(M3*3L) for M.2 x 1
- Breaket for HDMI x 2

1.2.22 System Power consumption

- 12-48VDC, 4.01-1.01A

1.2.23 System Block diagram

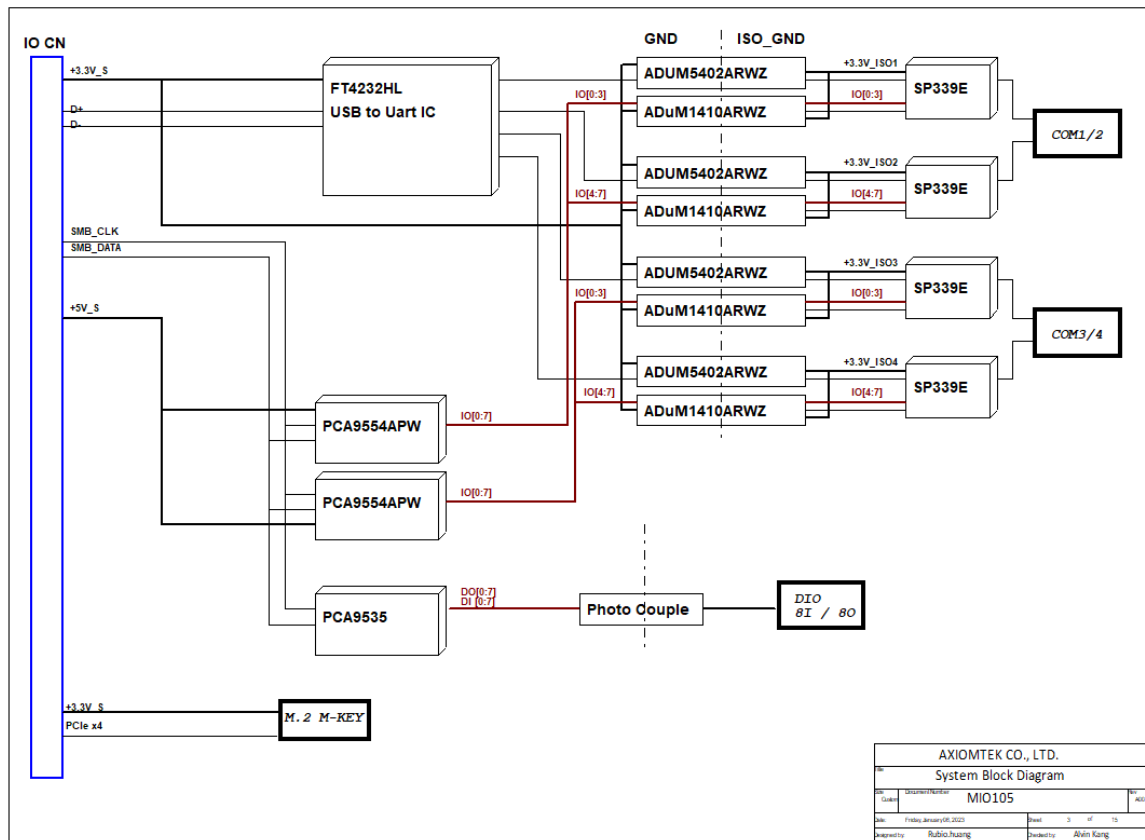
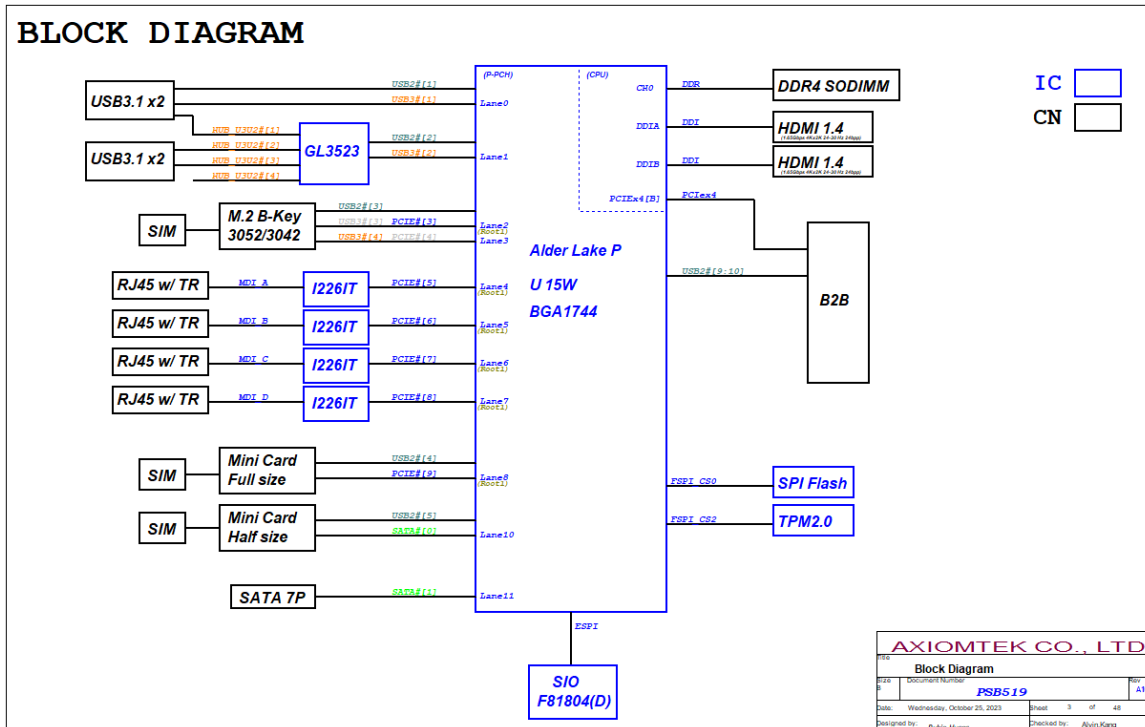

1.2.24 Placement

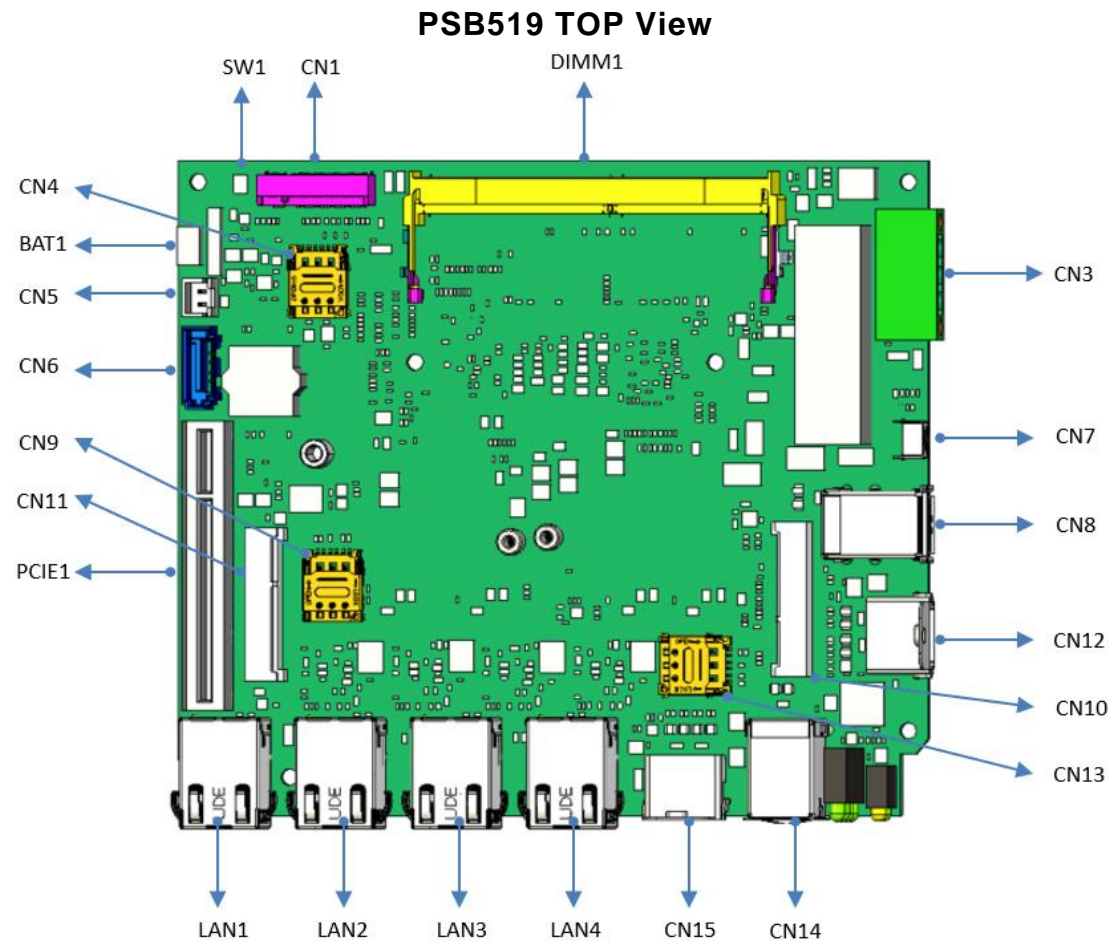

PSB519 Bottom View

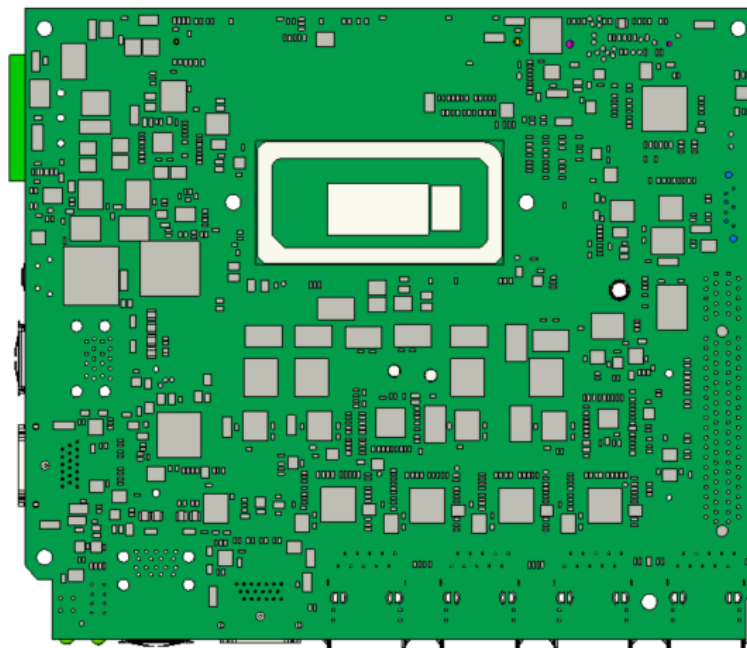

MIO105 TOP View

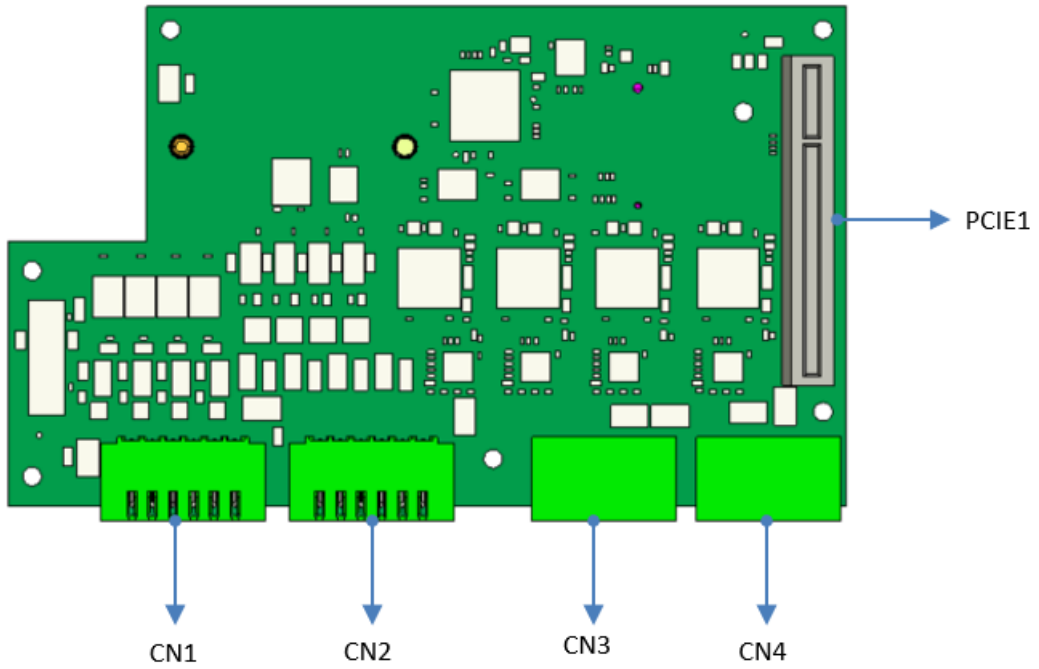

MIO105 Bottom View

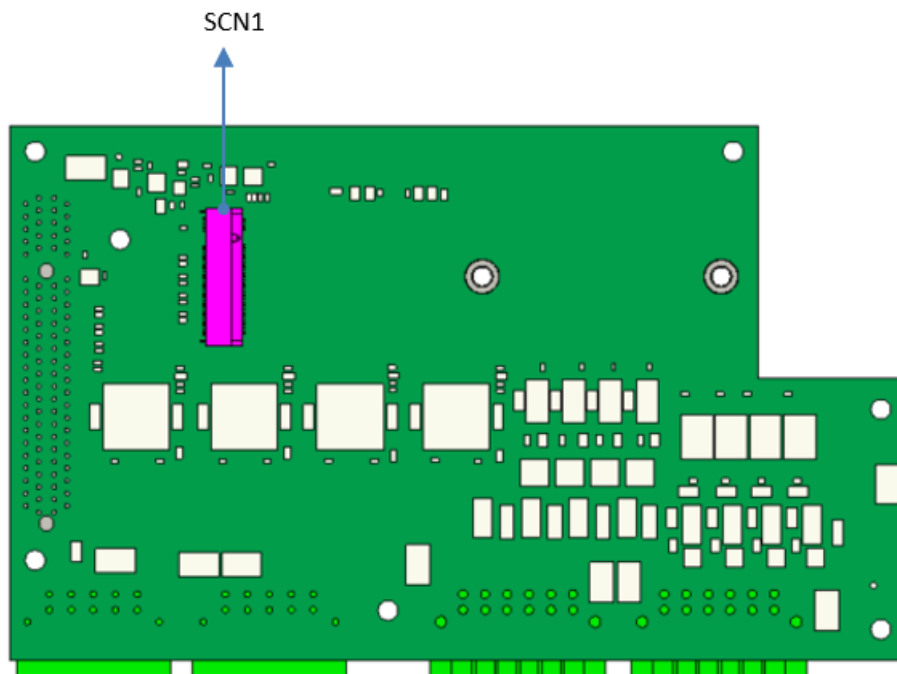

1.2.25 Connectors

Signals go to other parts of the system through connectors. Loose or improper connection might cause problems, please make sure all connectors are properly and firmly connected. Here is a summary table which shows all connectors on the hardware.

PSB519

Connectors	Label
3 pin terminal block for Power Input	CN3
Battery Connector	BAT1
DDR4 SODIMM Socket	DIMM1
HDMI output Connector	CN12/CN15
USB3.1 *2 Connector	CN8/CN14
LAN connector	LAN1/LAN2/LAN3/LAN4
M.2 B-key 3052/3042 (USB3.1 / PCIe interface)	CN1
Nano SIM card slot	CN4/CN9/CN13
Mini Card Solt1(USB2.0 / PCIe interface)	CN10
Mini Card Solt2(USB2.0 / mSATA interface)	CN11
Board-to-Board Connector	PCIE1
SATA+Power	CN5/CN6
Tact switch for clear CMOS	SW1
Tact switch for Reset	CN7

MIO105(Full Type)

Connectors	Label
Board-to-Board Connector	PCIE1
COM Port with RS232 / RS422 /RS485	CN1/CN2
Digital I Connector	CN3
Digital O Connector	CN4
NVMe M.2 2240/2280 PCIe Gen2x4	SCN1

1.3 Dimensions

The following diagrams show you the dimensions and outlines of the ICO520.

Fully Type

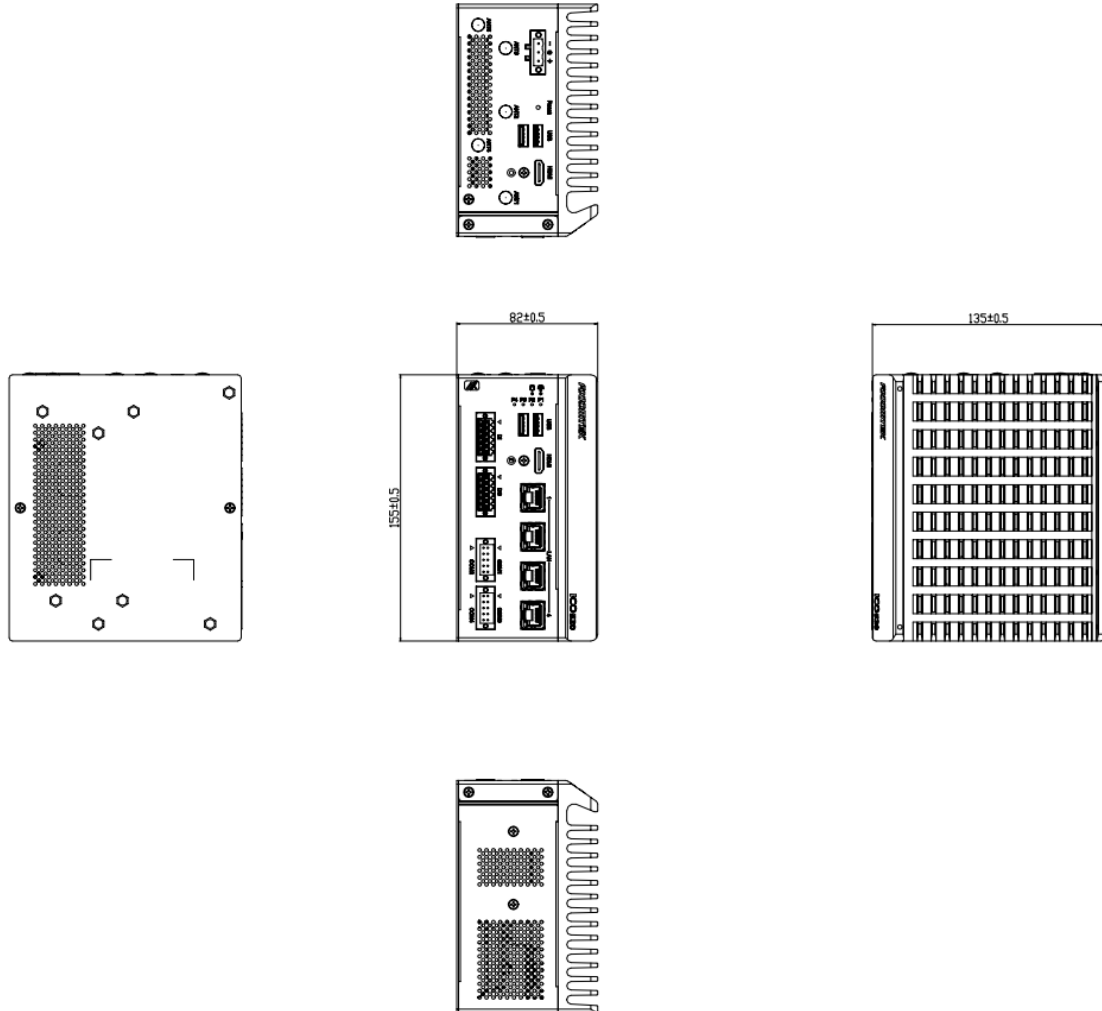

1.4 I/O Outlets

The following figures show you I/O outlets on the front view, top view and bottom view of the ICO520.

Type	Fully	Simplified
Front		
Top		

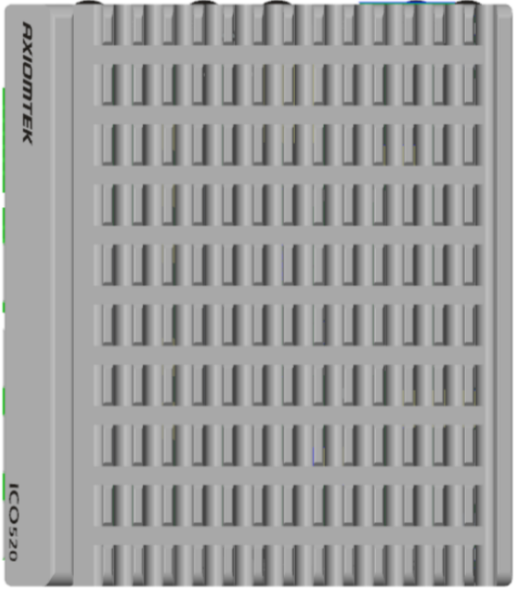
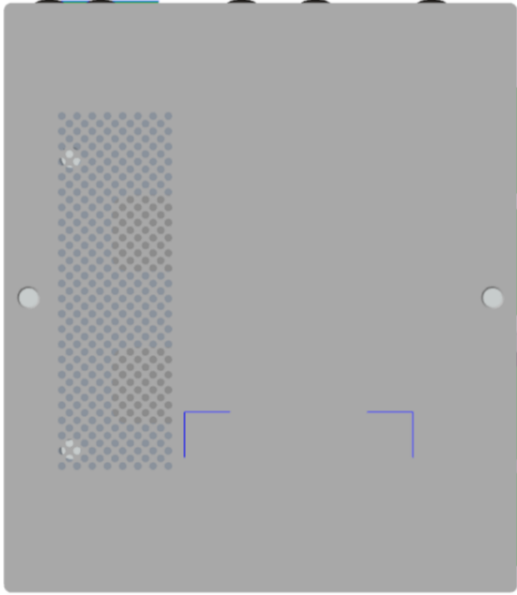
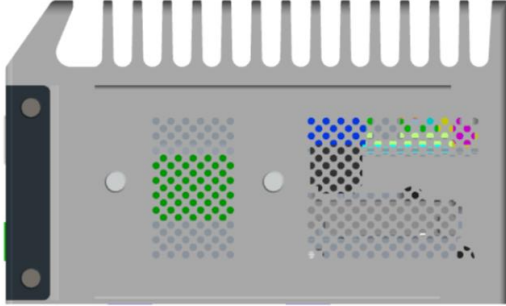
Right	
Left	
Bottom	

SECTION 2 HARDWARE INSTALLATION

The ICO520 is flexible for your different hardware configurations, such as the memory module, hard disk drive, mini card and I/O module. Chapter 2 will show you how to install the hardware.

2.1 Installing the Memory & Wireless Module

Step 1 Turn off the system.

Step 2 Loosen all cover screws and remove the cover from the system.

Fully Type

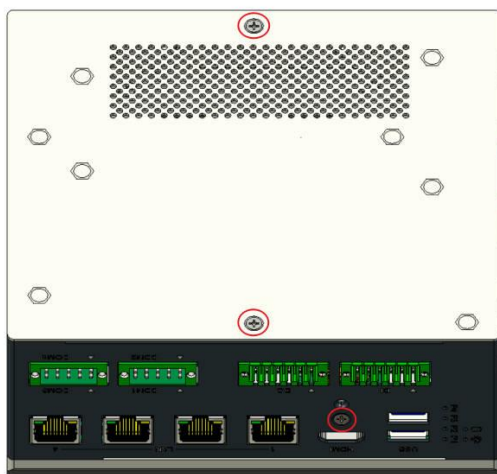

Simplified Type

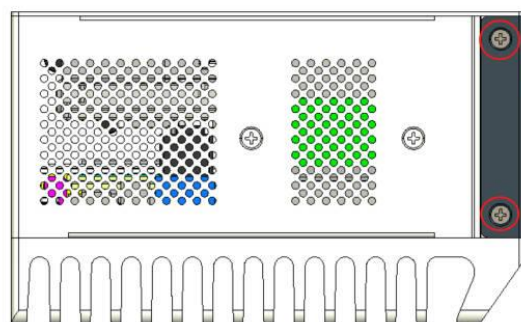
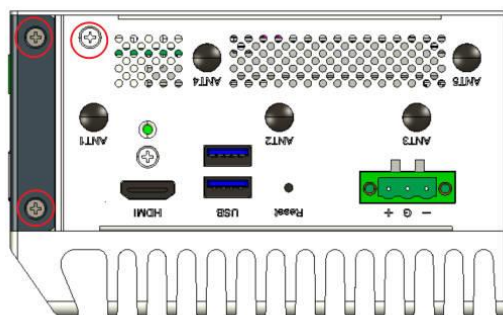
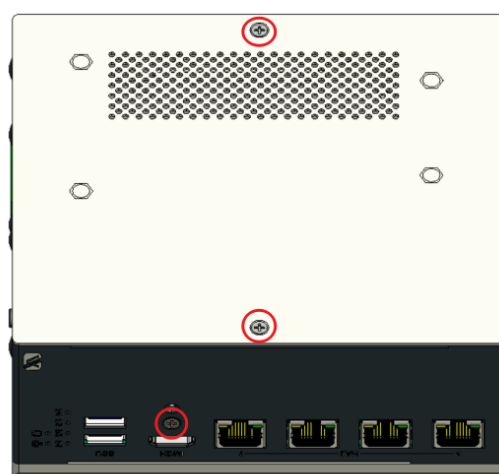

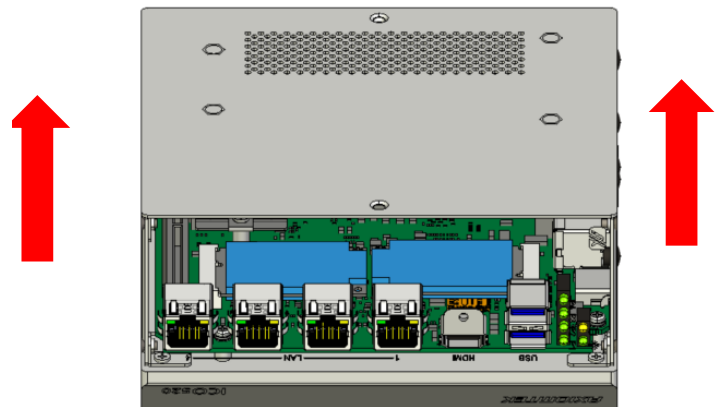
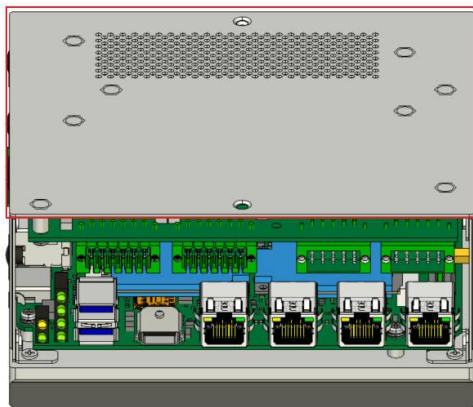
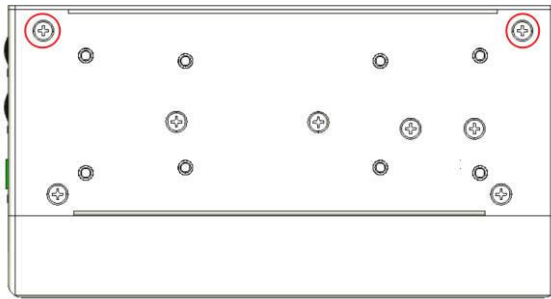

Step 3 Put the thermal pad on the SO-DIMM socket. Then insert the module's gold finger into the socket and push the module down to finish the memory installation.

a. Paste Sponge

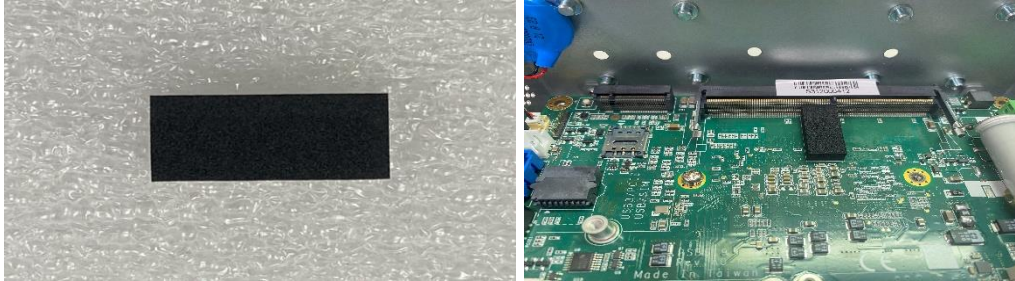

b. Install Memory

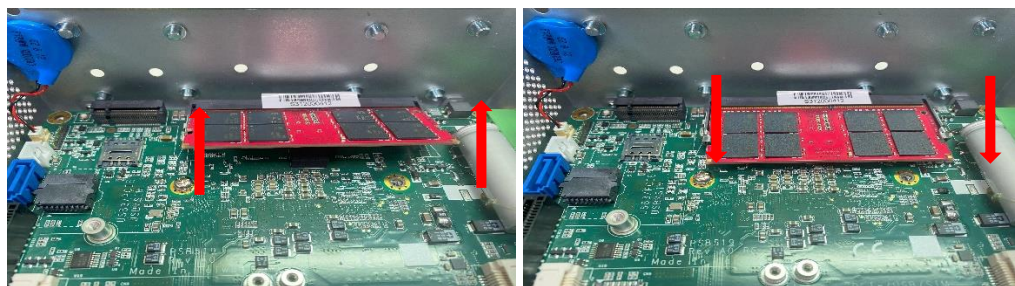

c. Install thermal pads and sheets

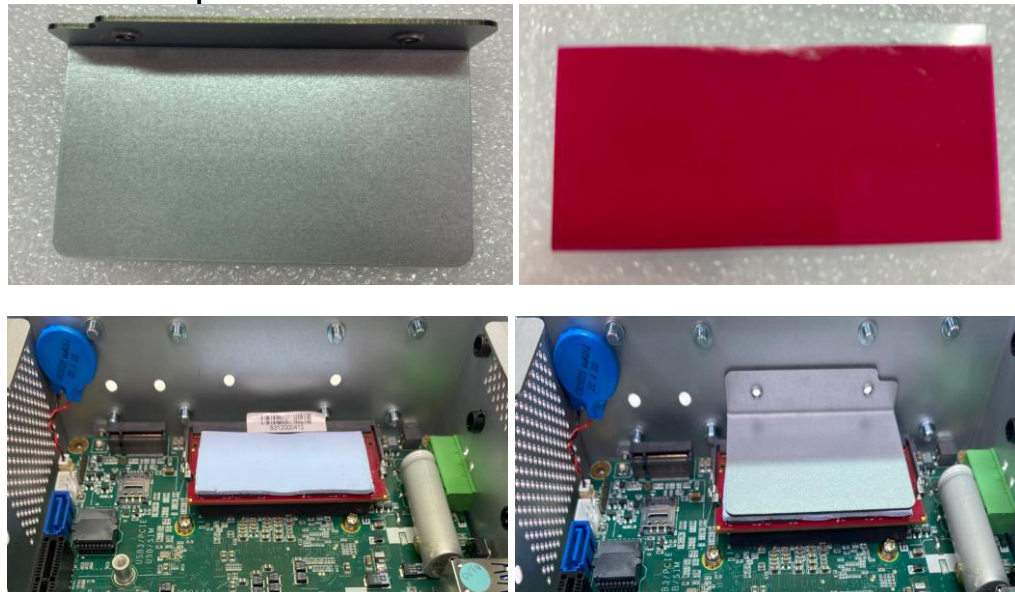

d. Tighten the screw

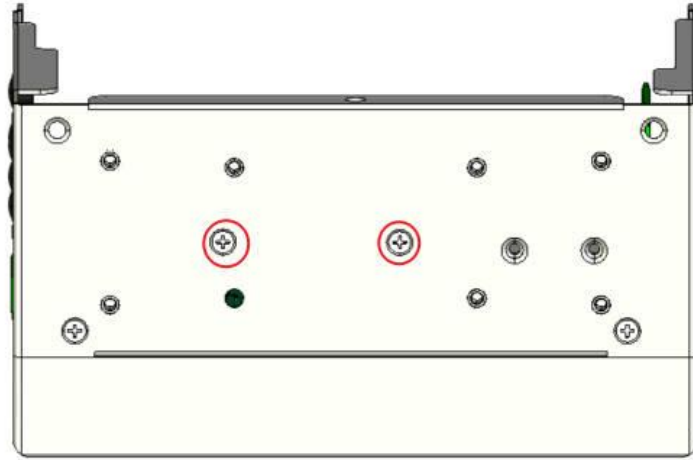

Step 4 Insert the PCIe/USB Card into the socket and fasten screws. (Note: For the mini card with SIM function, the PCIe card should be inserted into (Socket10 · 11)

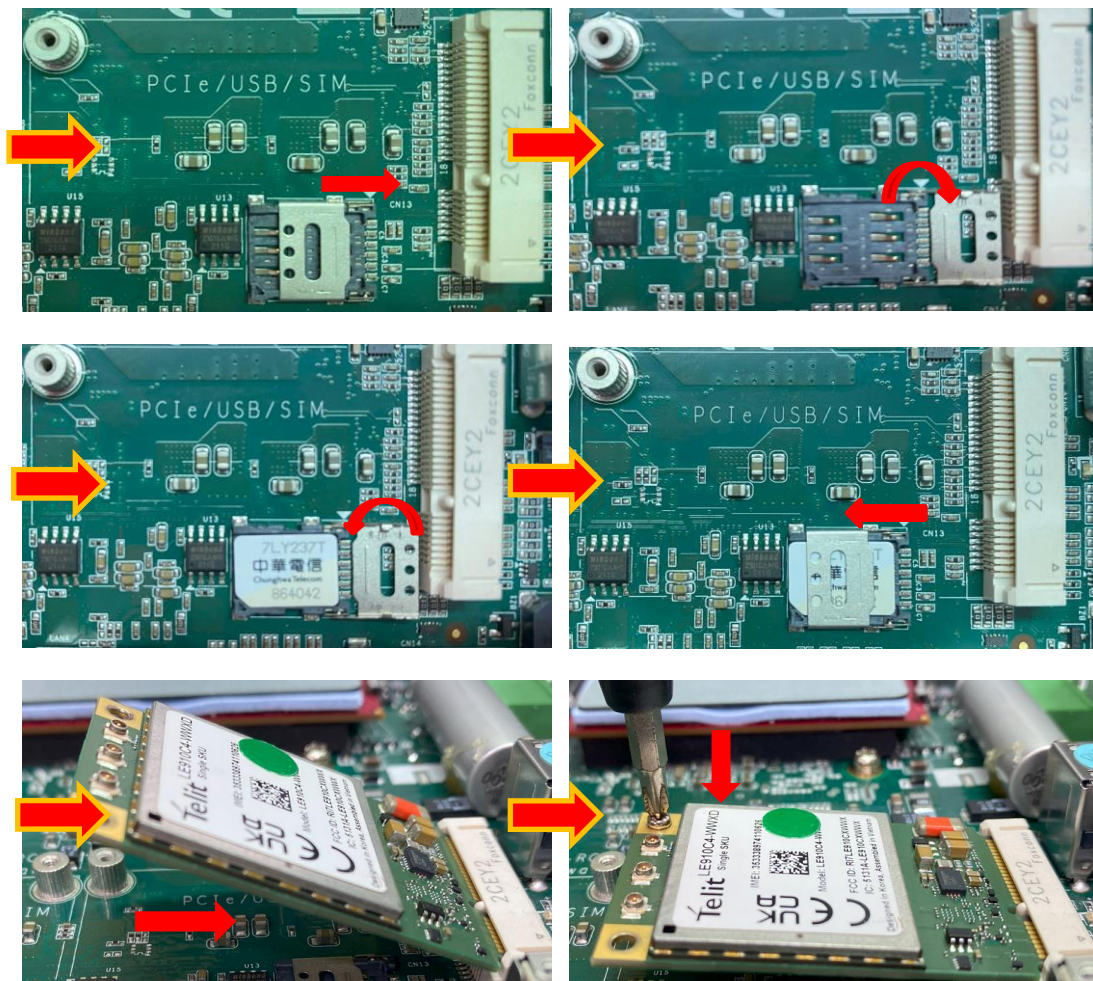

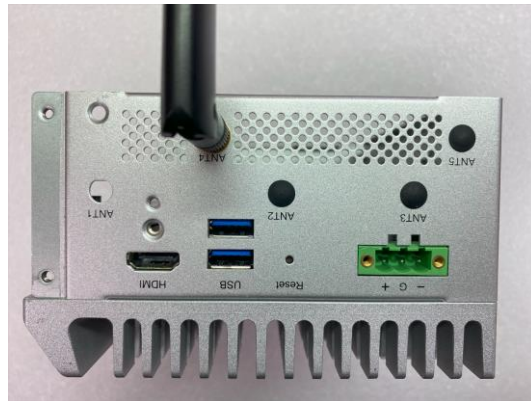

Put the cover back onto the system, and fasten all screws tightly to close the chassis.

**Step 5 Insert the M.2 Key B 3050/3052 slot: PCIe/USB (for 5G/Wi-Fi)
(Socket CN1)**

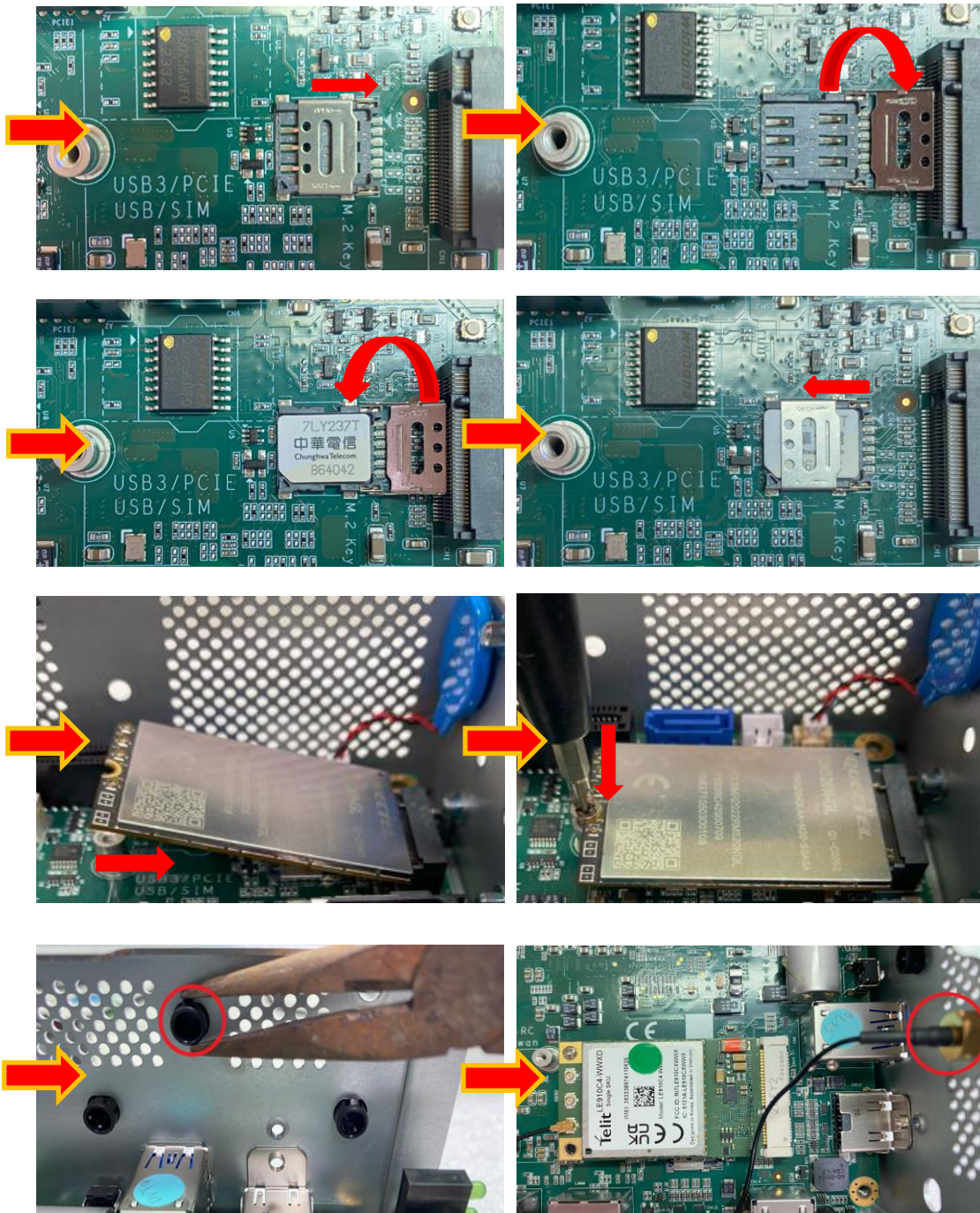

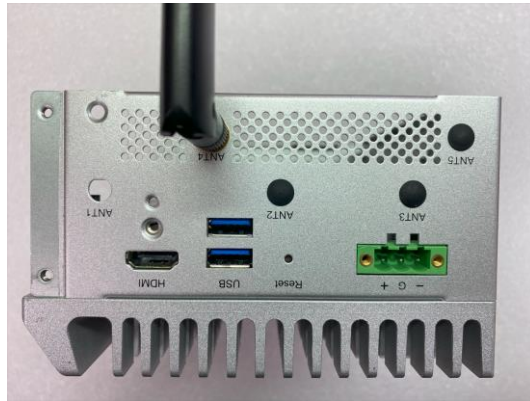

Put the cover back onto the system, and fasten all screws tightly to close the chassis.

2.2 Installing the Hard Disk 、 NVMe Drive

Step 1 Turn off the system.

Step 2 Loosen the screw as shown below, and pull out the SSD 、 NVMe tray from the system.

Fully Type

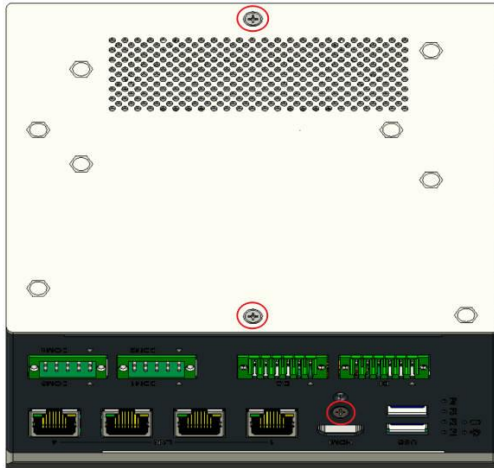

Simplified Type

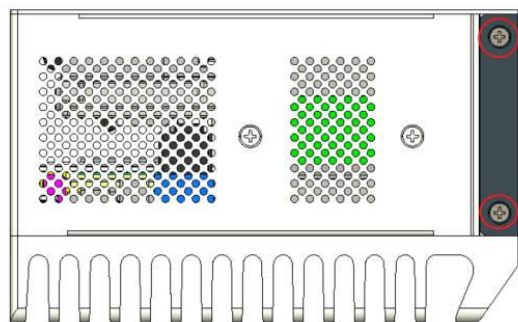
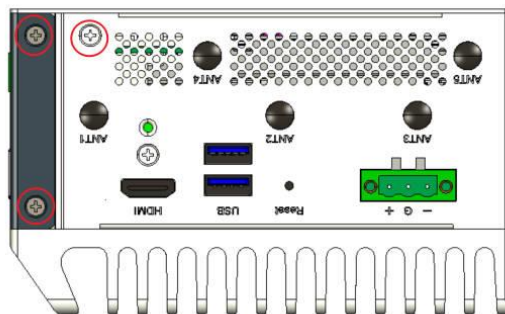
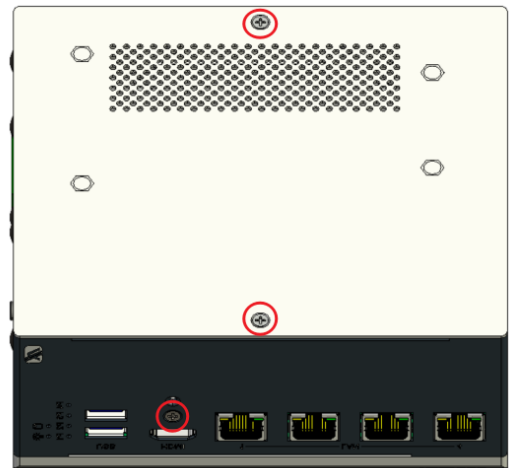

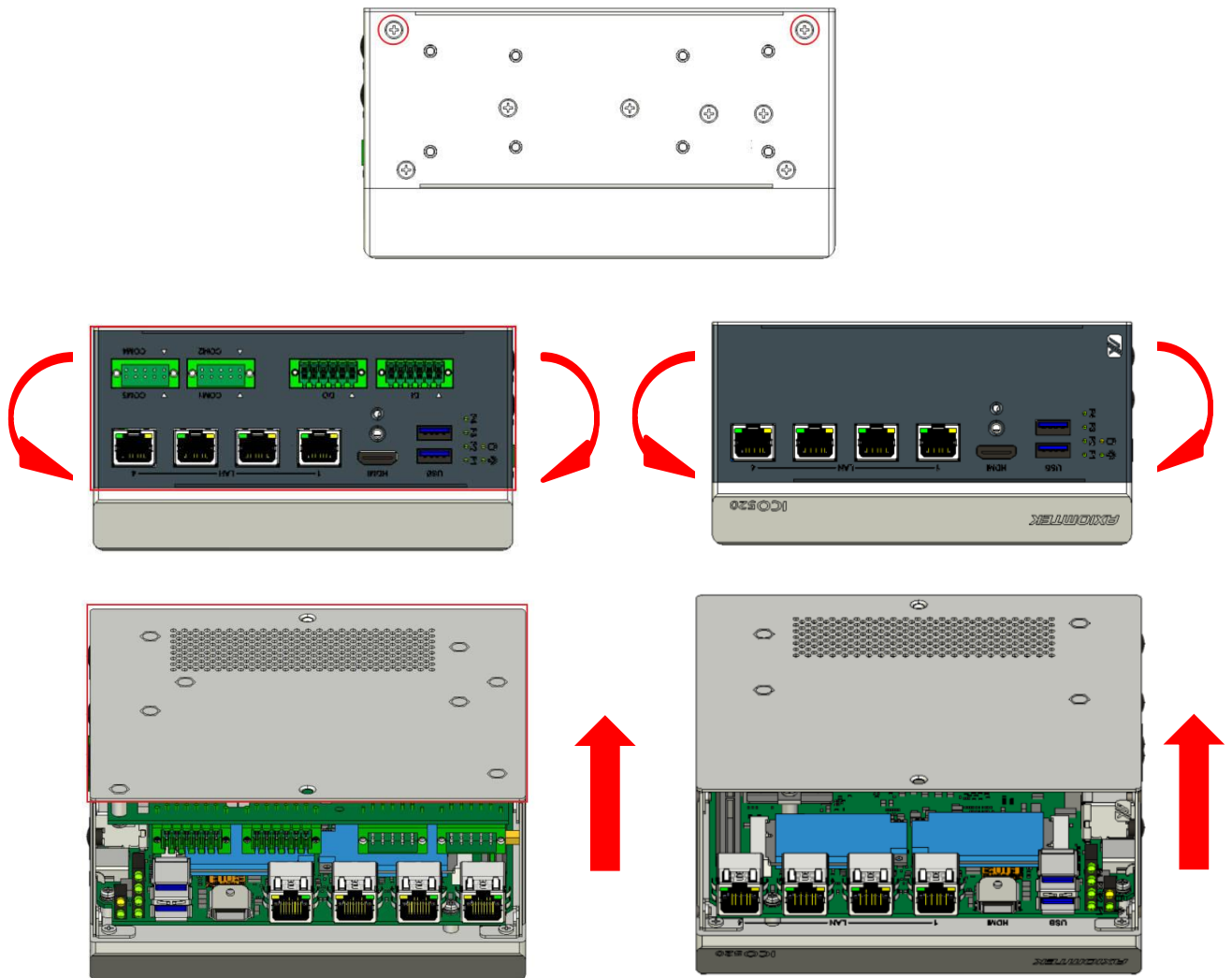

a. SSD

Fully Type

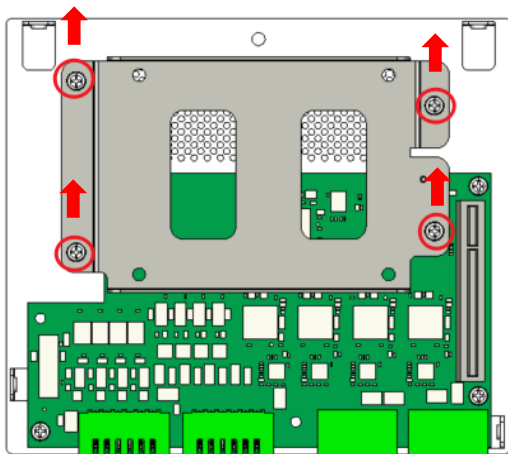

Simplified Type

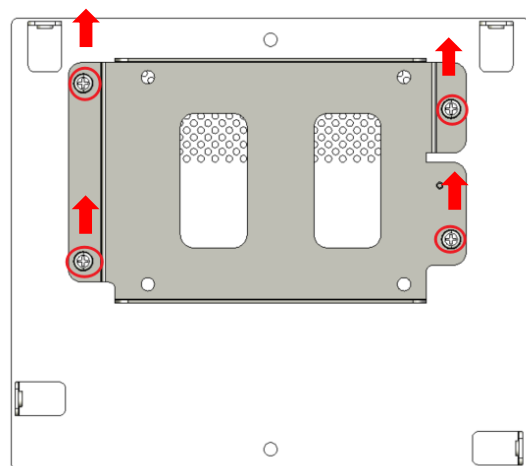

b. NVMe For Fully Type/ Simplified Type

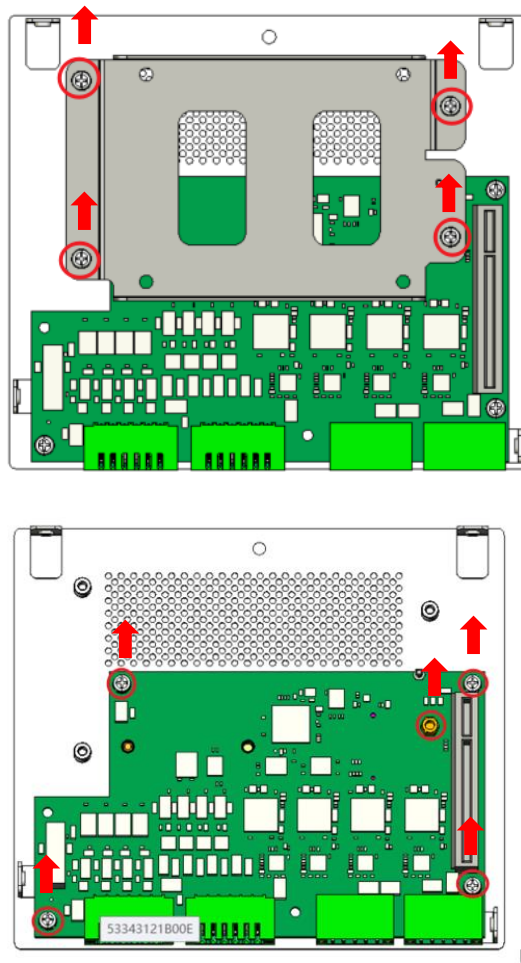

Step 3 Fasten the SSD screws (marked by the red arrows below) to fix the SSD. Then screw the SSD install the tray back to the system.

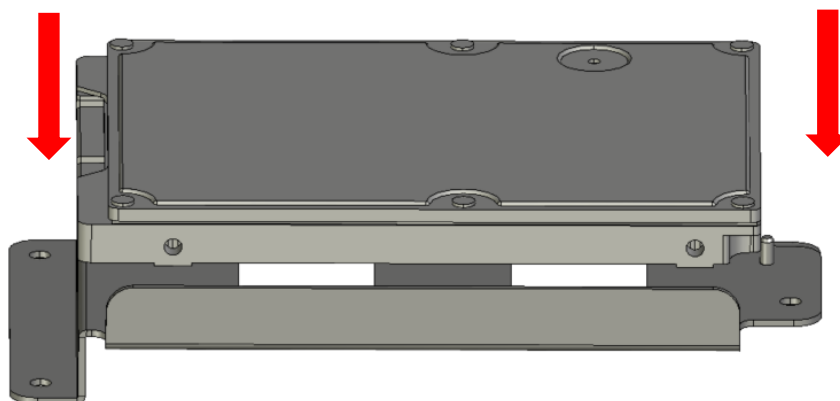

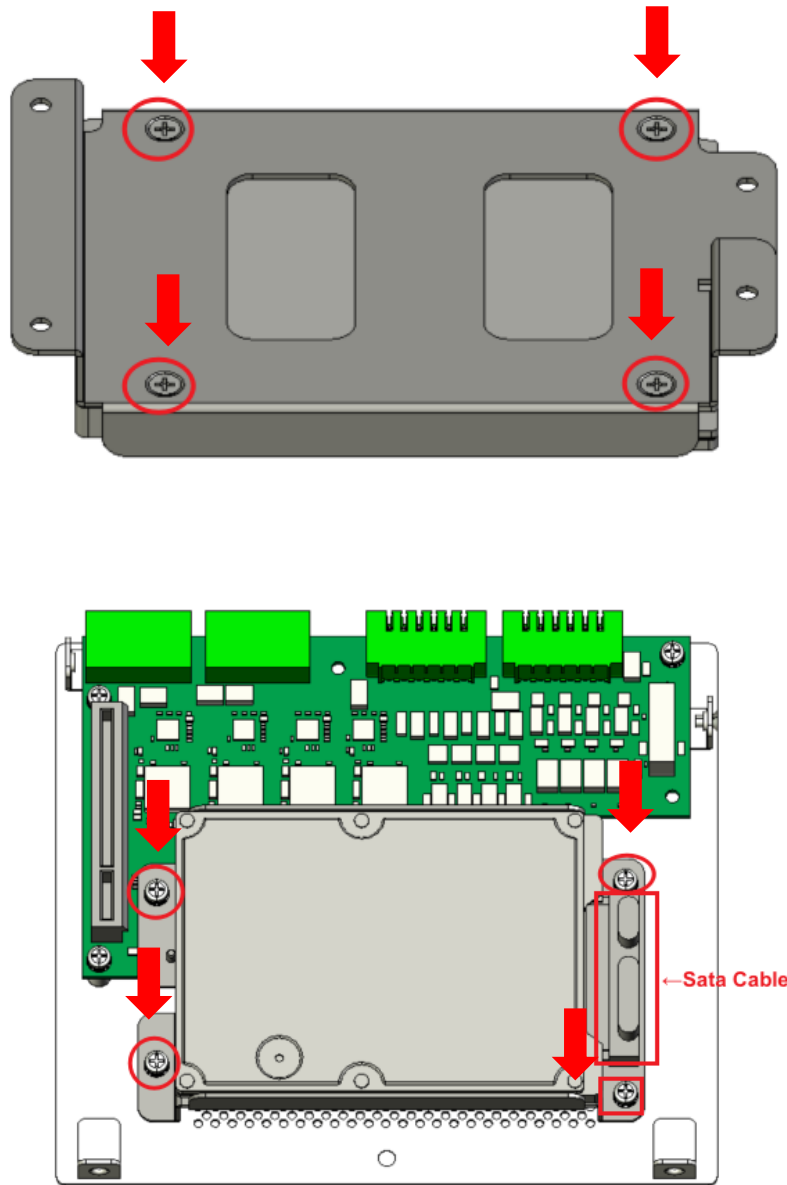

Step 4 Fasten the NVMe(M.2 Key B 3050/3052) screws (marked by the red arrows below) to fix the NVMe(M.2 Key B 3050/3052). Then screw the NVMe(M.2 Key B 3050/3052) install the tray back to the system.

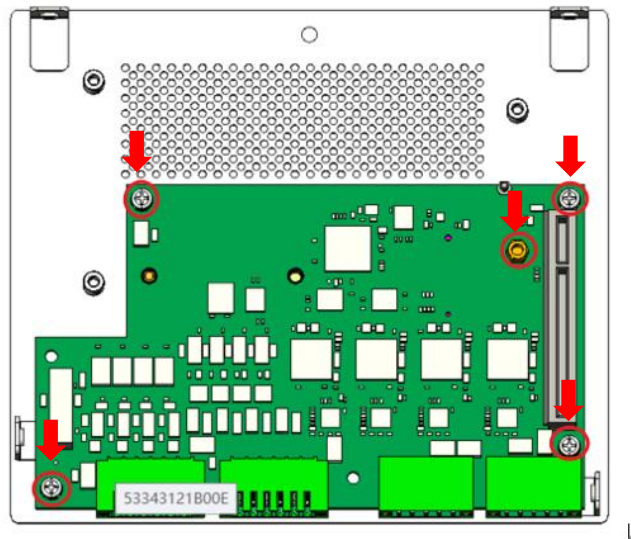
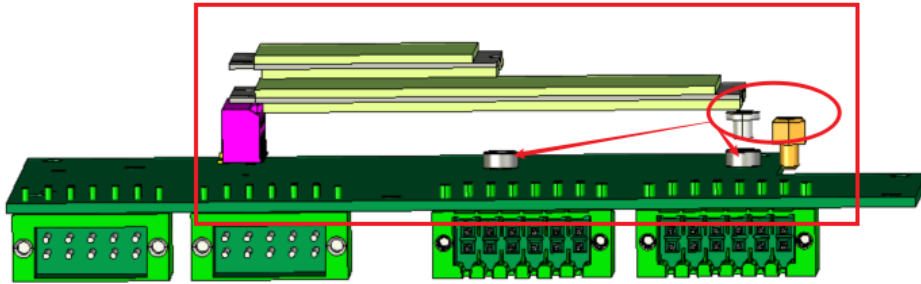

2.3 Installing the DIN-rail Mounting Kit

Step 1 Prepare the DIN-rail Mount assembly components (screws and bracket) ready.

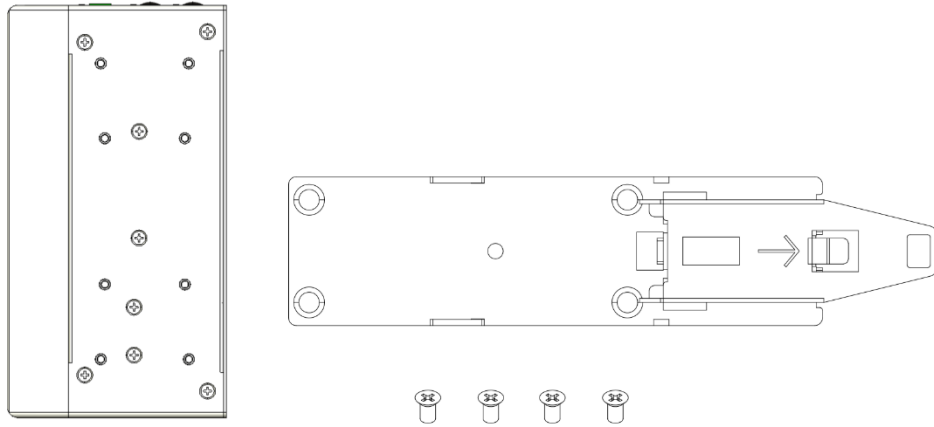

Step 2 Assemble the bracket to the system and fasten screws tight.

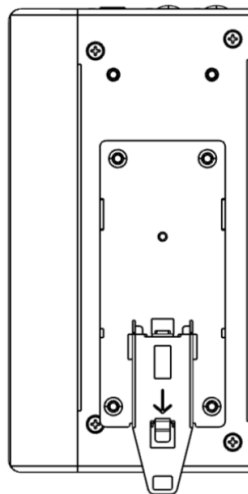

This page is intentionally left blank.

CHAPTER 3

AMI UEFI BIOS UTILITY

The AMI UEFI BIOS provides users with a built-in Setup program to modify basic system configuration. All configured parameters are stored in a flash-backed-up to save the Setup information whenever the power is turned off.

3.1 Entering Setup

To enter the setup screens, follow the steps below:

1. Turn on the computer and press the key immediately.
2. After you press the key, the main BIOS setup menu displays. You can access the other setup screens from the main BIOS setup menu, such as the Advanced and Chipset menus.

3.2 The Main Menu

Once you enter the AMI BIOS Aptio Setup Utility, the Main Menu appears on the screen. In the Main Menu, there are several Setup functions and a couple of Exit options for your selection. Use Select Screen Keys (or Move Keys) to select the Setup Page you intend to configure and then press <Enter> to accept or enter its sub-menu.

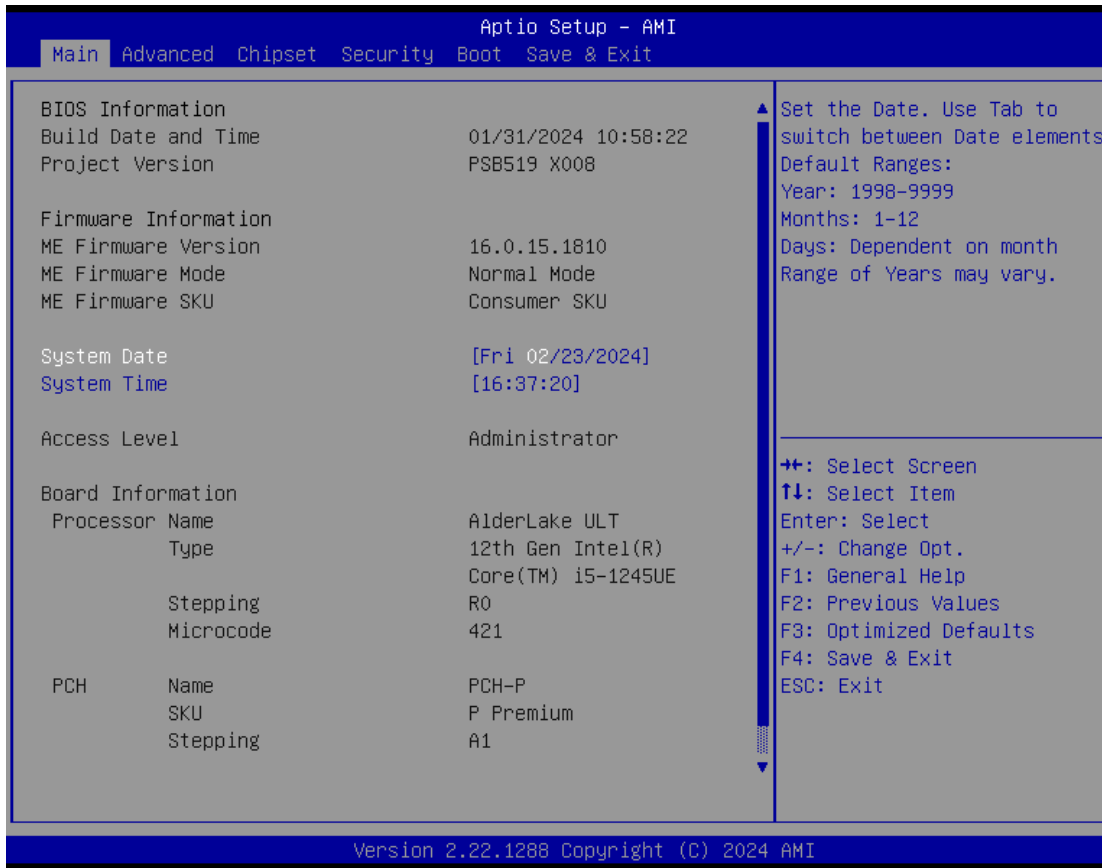

System Date

The date format is <day> <month> <date> <year>.

System Time

This item shows current time of your system with the format <hour> <minute> <second>. The time is calculated based on the 24-hour military-time clock. For example, 1 p.m. is 13:00:00.

3.3 Advanced Features

The Advanced menu also allows users to set configuration of the CPU and other system devices. Users can select any items in the left frame of the screen to go to sub menus:

- ▶ Hardware Monitor
- ▶ Trust Computing
- ▶ CPU configuration
- ▶ Storage Configurations
- ▶ USB Configuration
- ▶ Device Configuration

For items marked with “▶”, please press <Enter> for more options.



- **Hardware Monitor**

This screen displays the temperature of CPU and system, as well as system voltages (+3.3V, +12V and +5V ,etc).

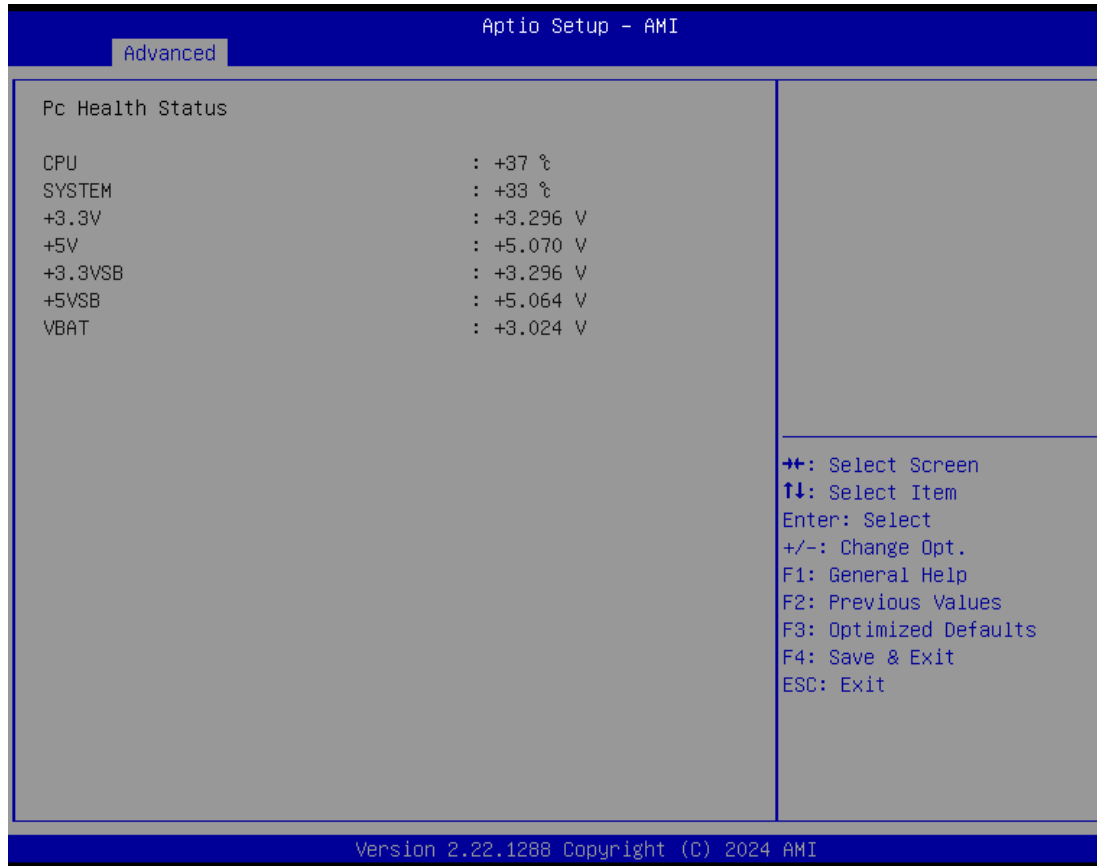

● **Trusted Computing**

In terms of Trusted Platform Module Device, users can choose between disabling TPM and enabling Platform Trust Technology.

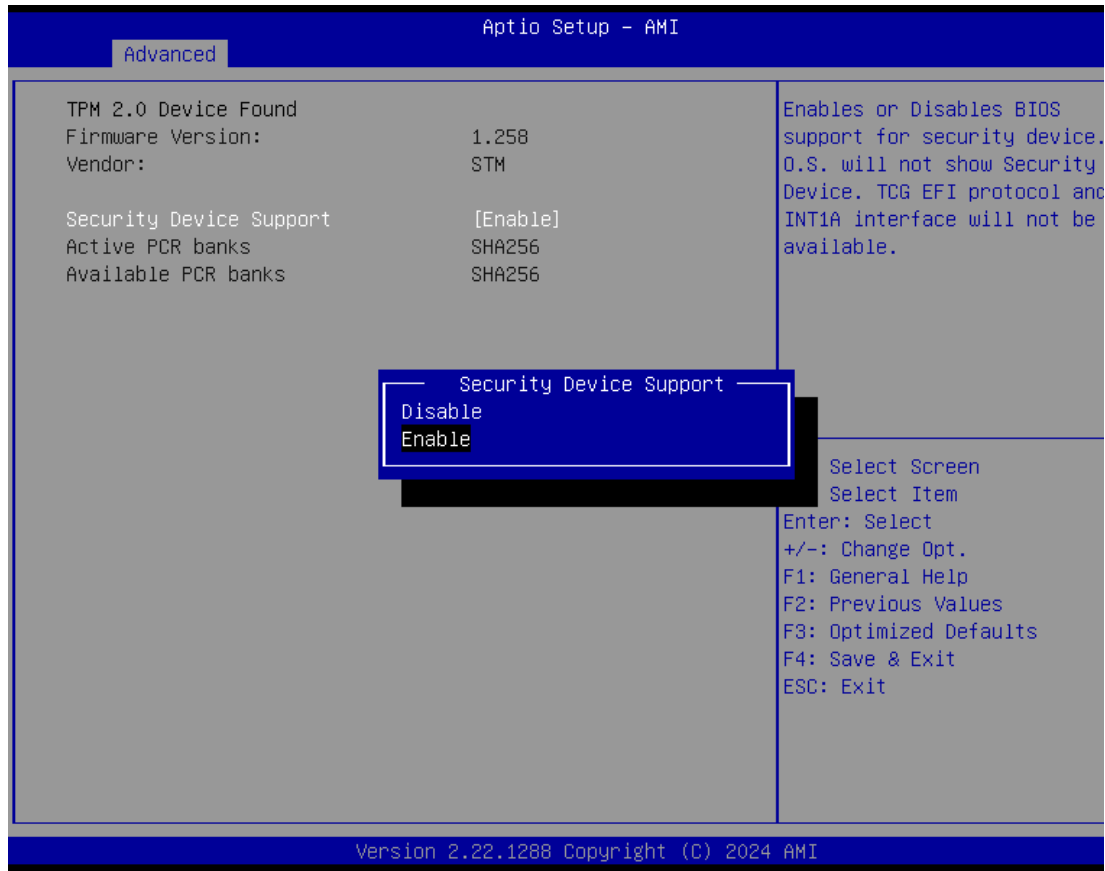

Security Device Support

Enable or disable BIOS support for security device, see image below. OS will not show security device. TCG EFI protocol and INT1A interface will not be available.

- **CPU Configuration**

This screen shows the CPU version and its detailed information.

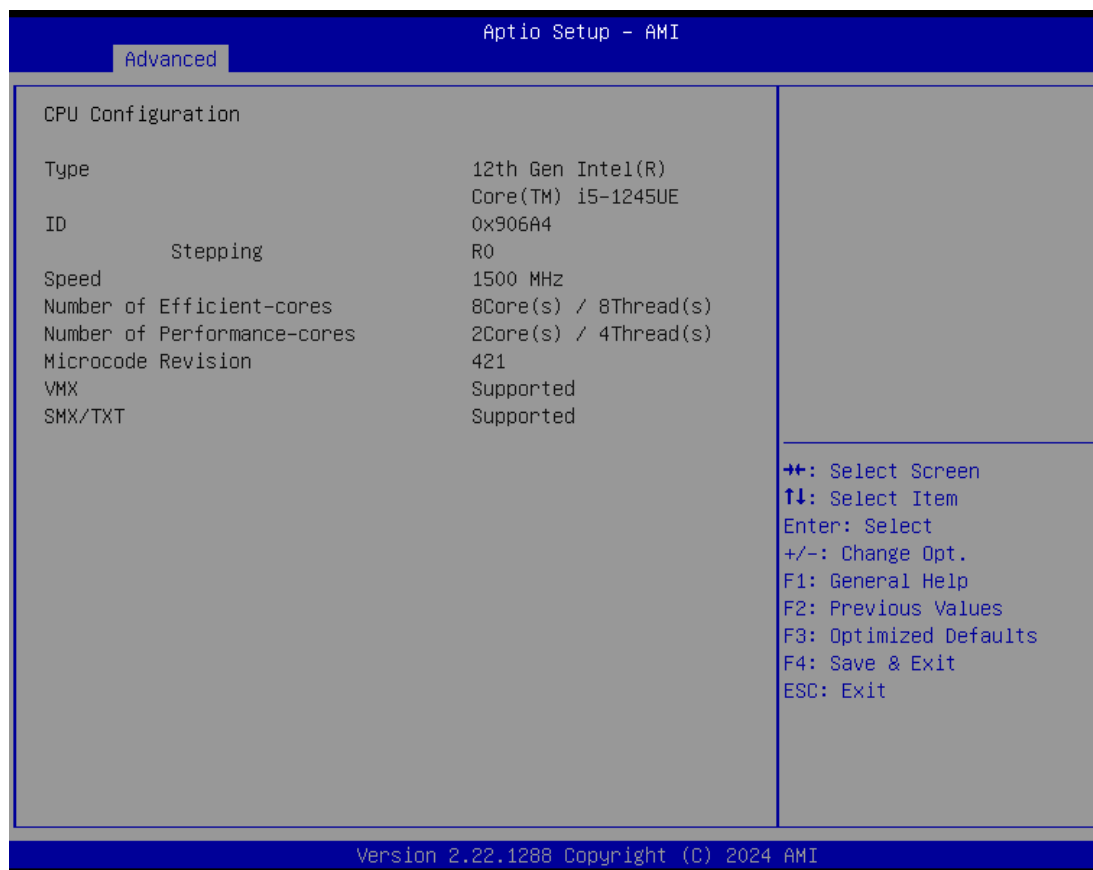

● **Storage Configuration**



- **SATA Configuration**

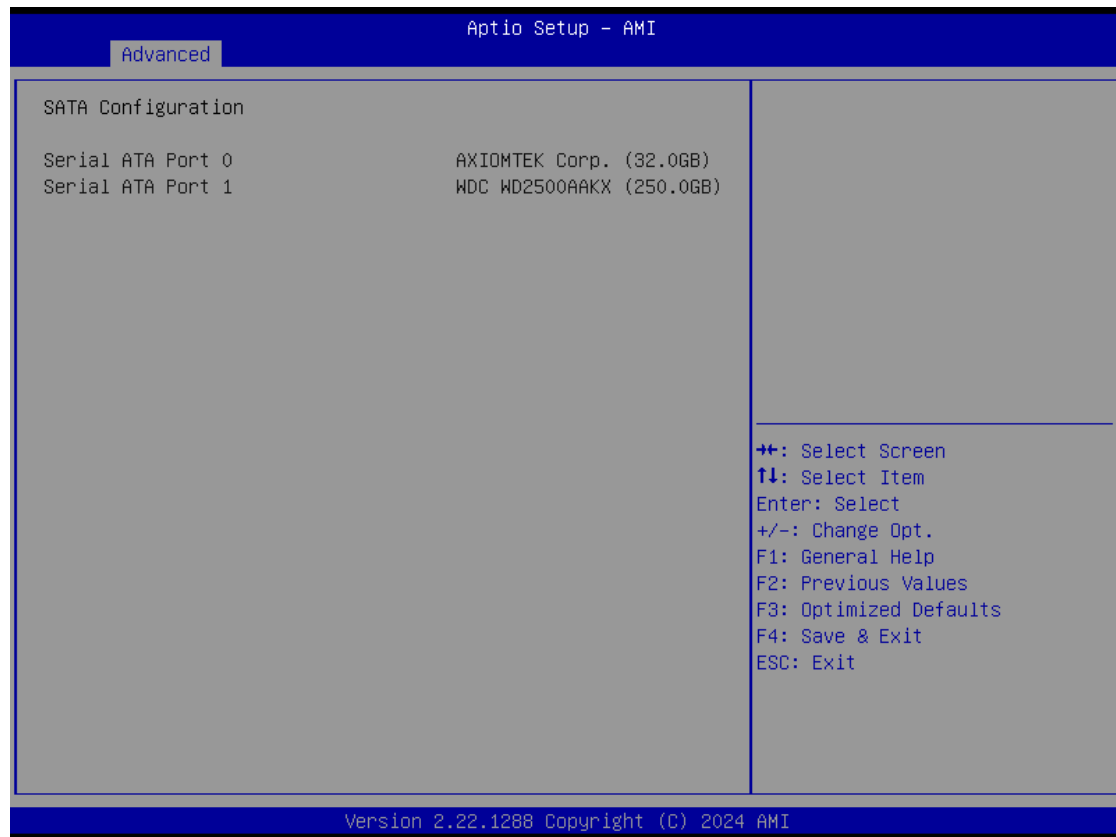

Serial ATA Port 0~1

It shows the device installed in connector SATA0~1.

● **NVMe Configuration**

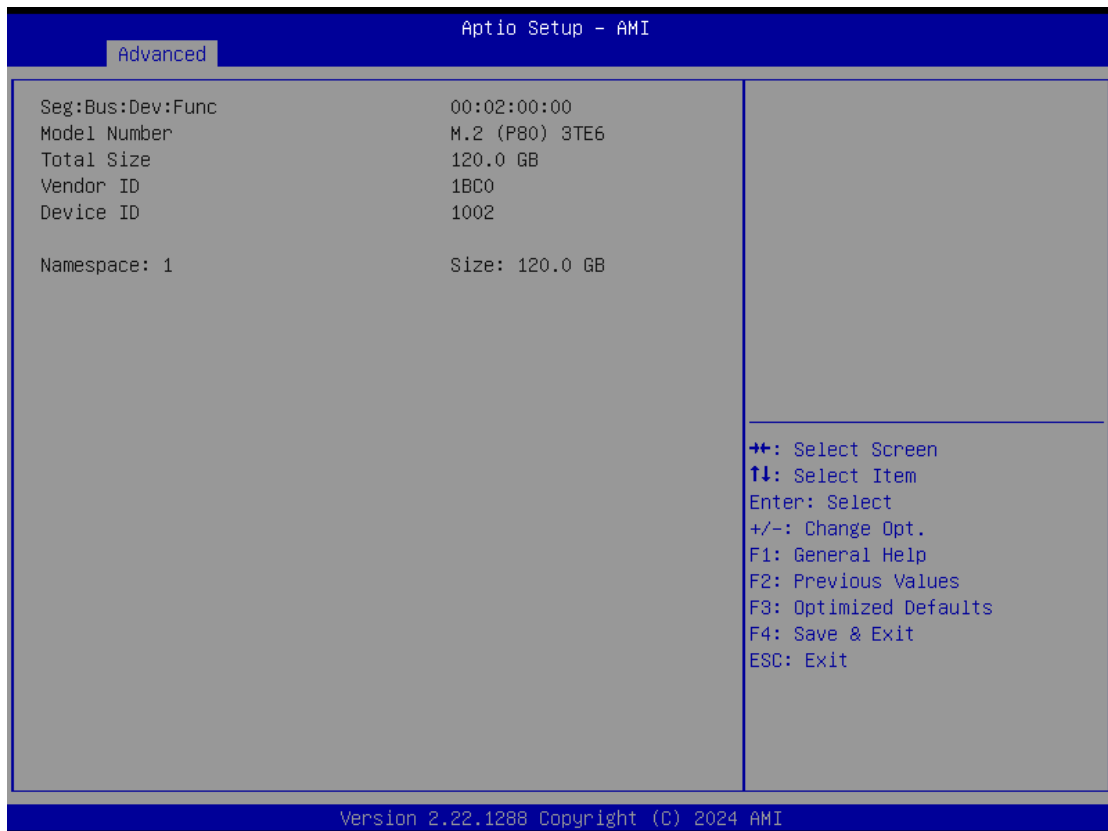
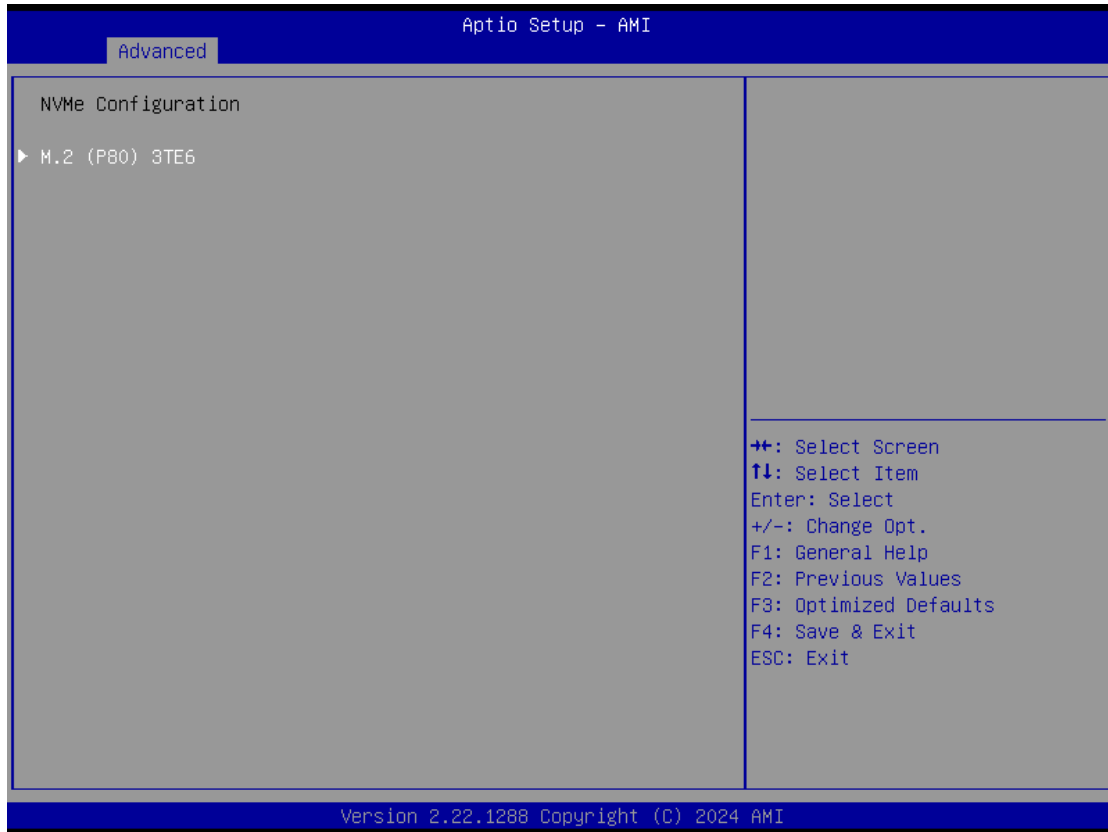

USB Configuration

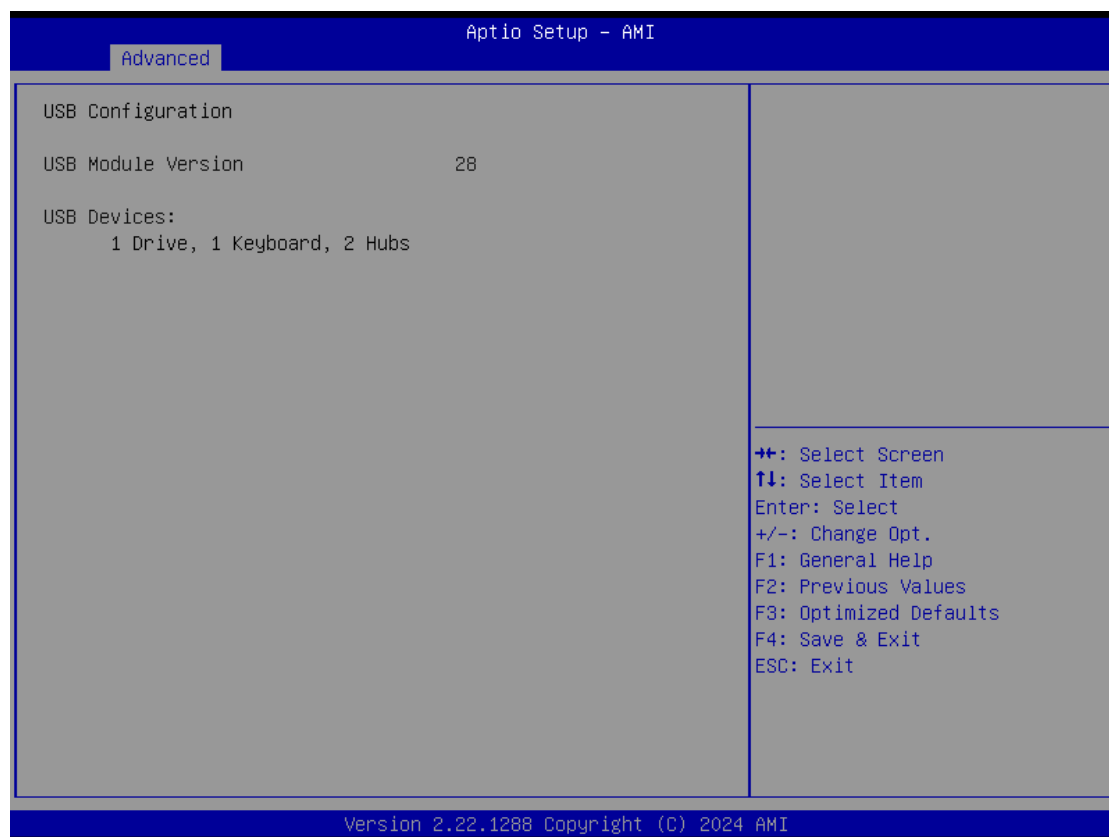

USB Configuration

USB Devices Display all detected USB devices.

- **Device Configuration**

Device configuration divides into two parts: one part is onboard device; the other is module device.

The Module Device Configuration menu would dynamically appear when a module device is plugged into the slot. When no module is plugged in, the screen would only show Onboard Device Configuration.

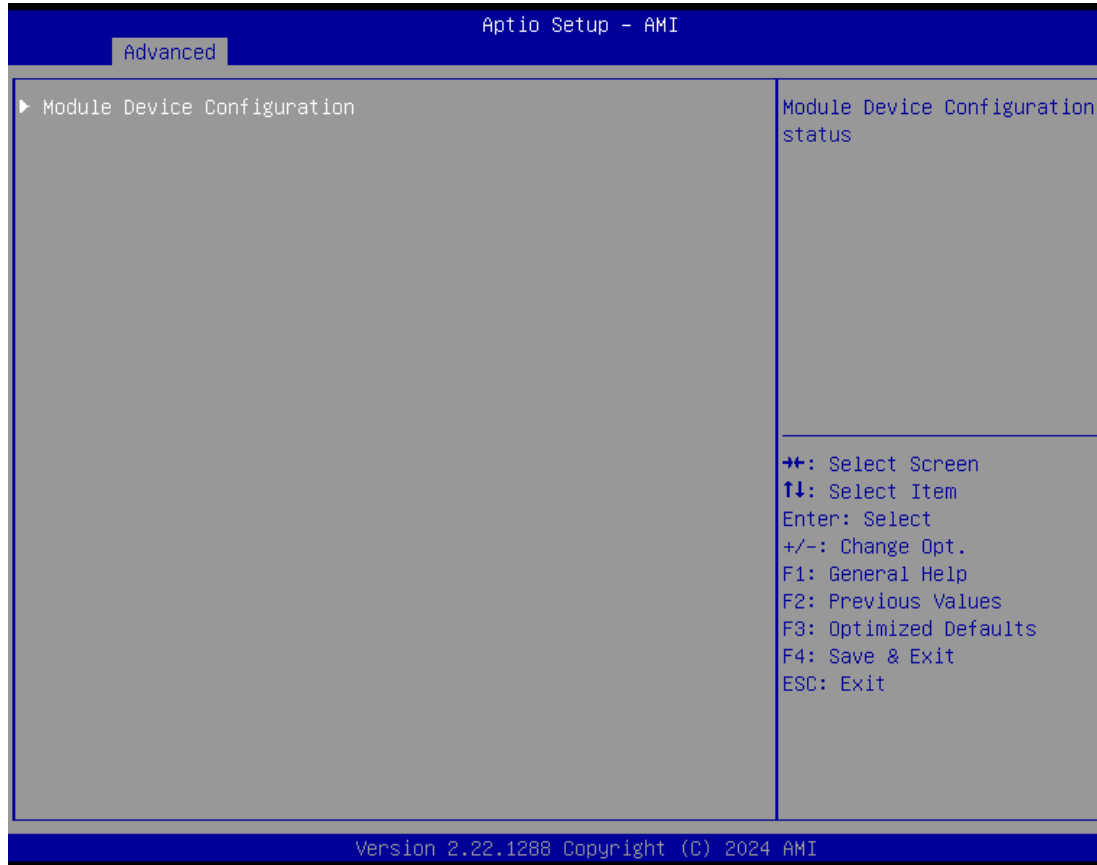

- **Module COM port Configuration**

When the module have COM port functions, the module COM configuration menu would show.

The default setting for all Serial Ports is RS232.

You can change the setting by selecting the value you want in each COM port type. The system supports RS422 & RS485 mode and high speed mode.

(Please refer below graphics.)



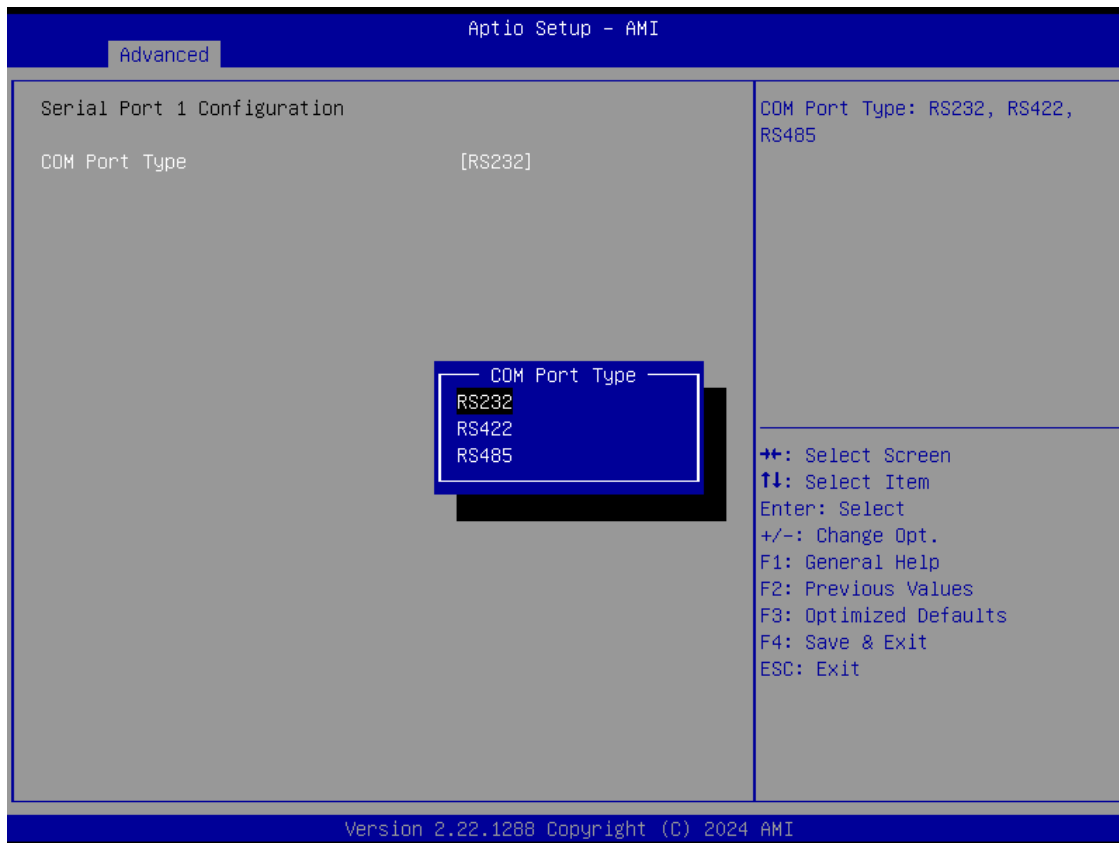
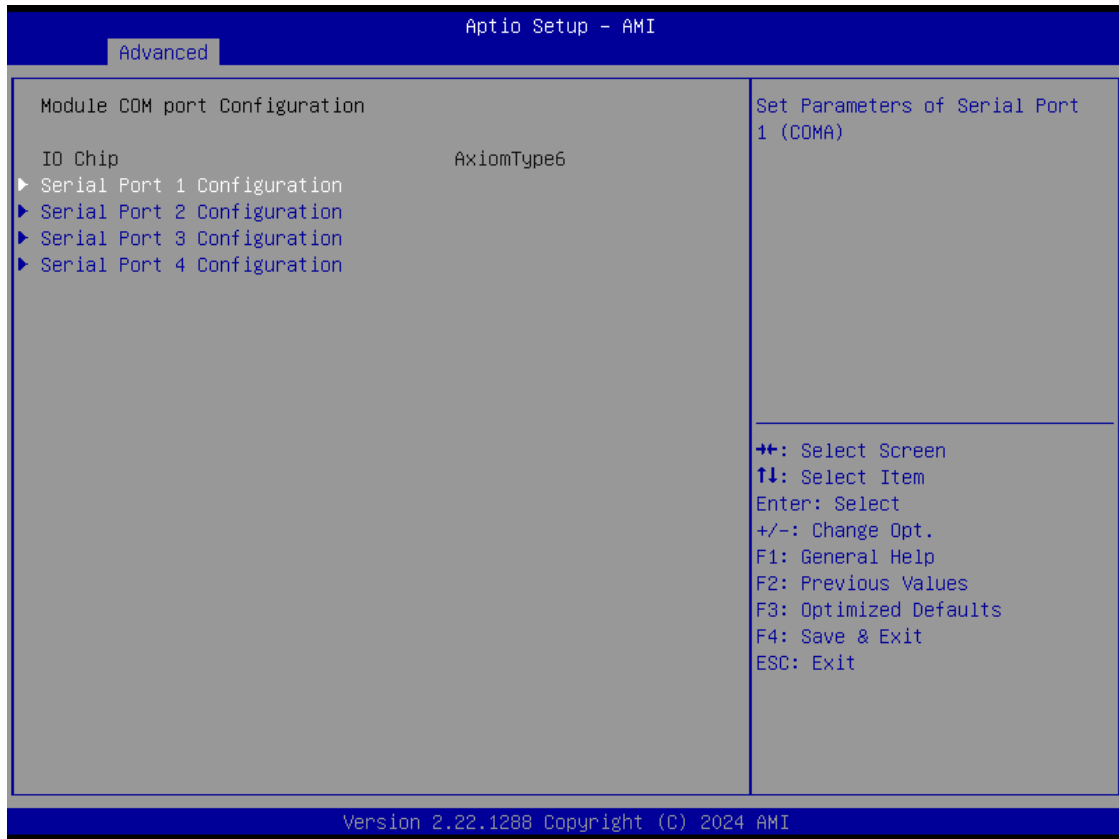

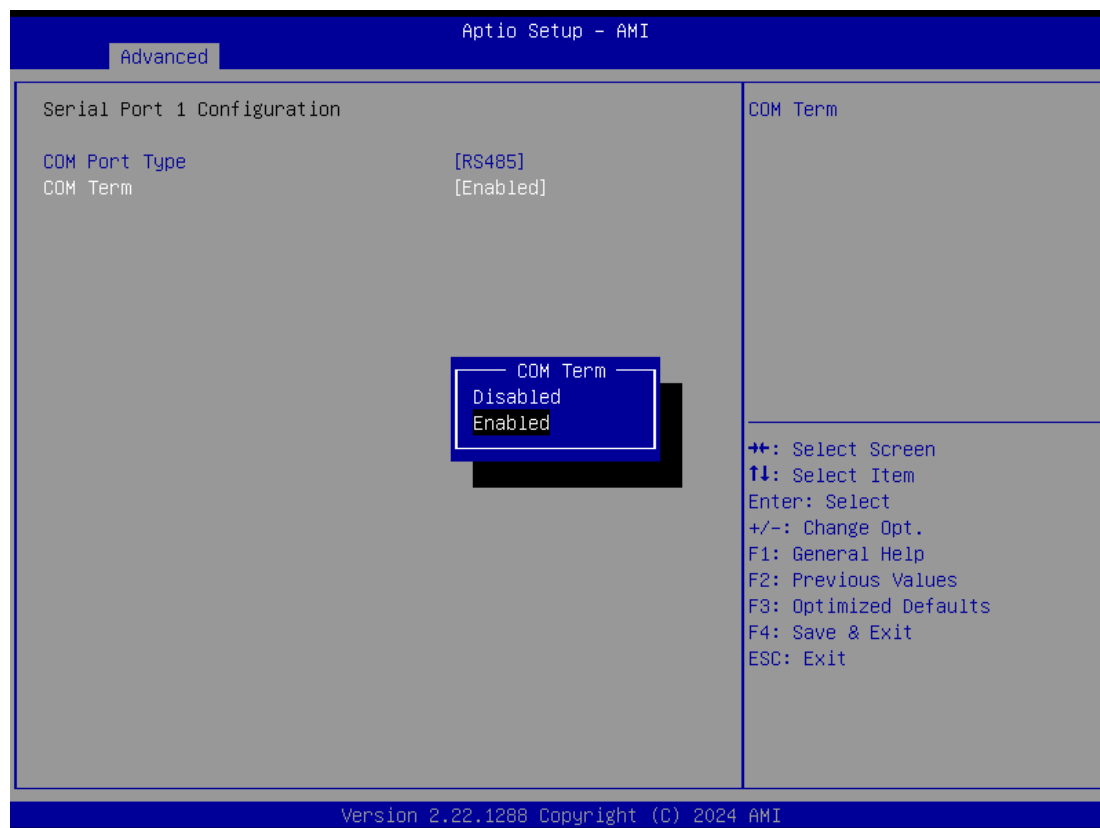

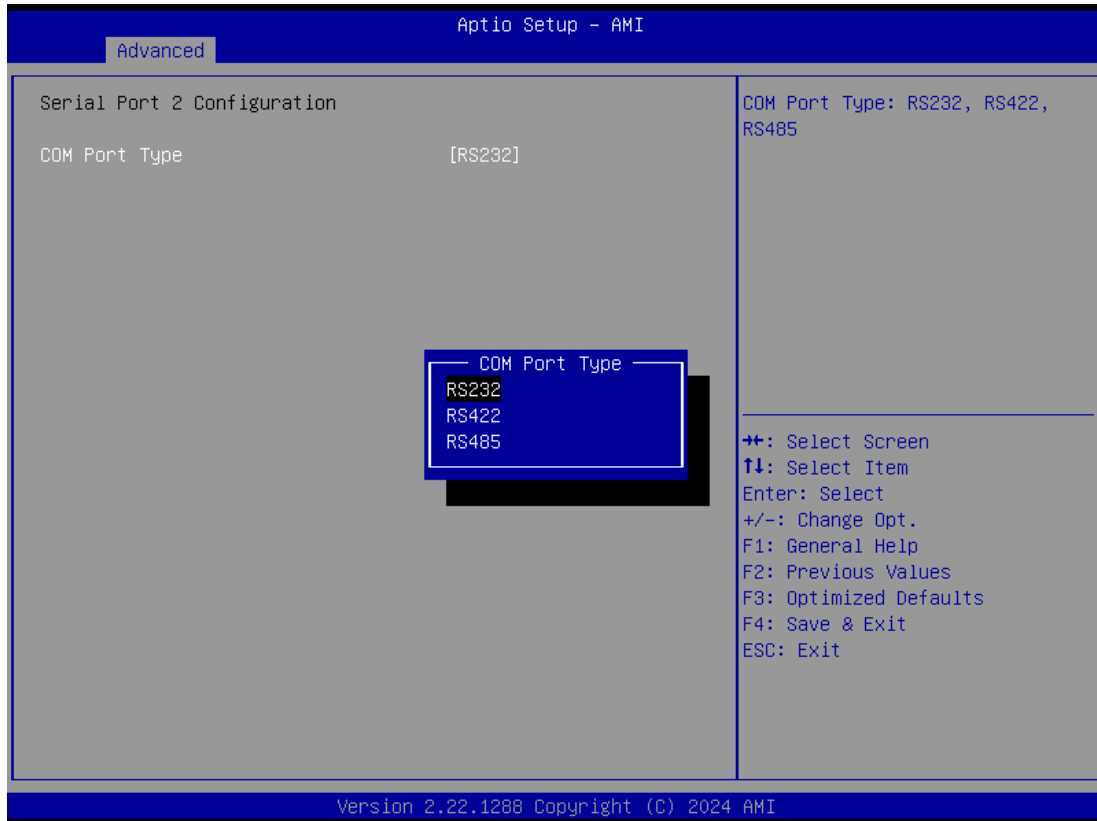

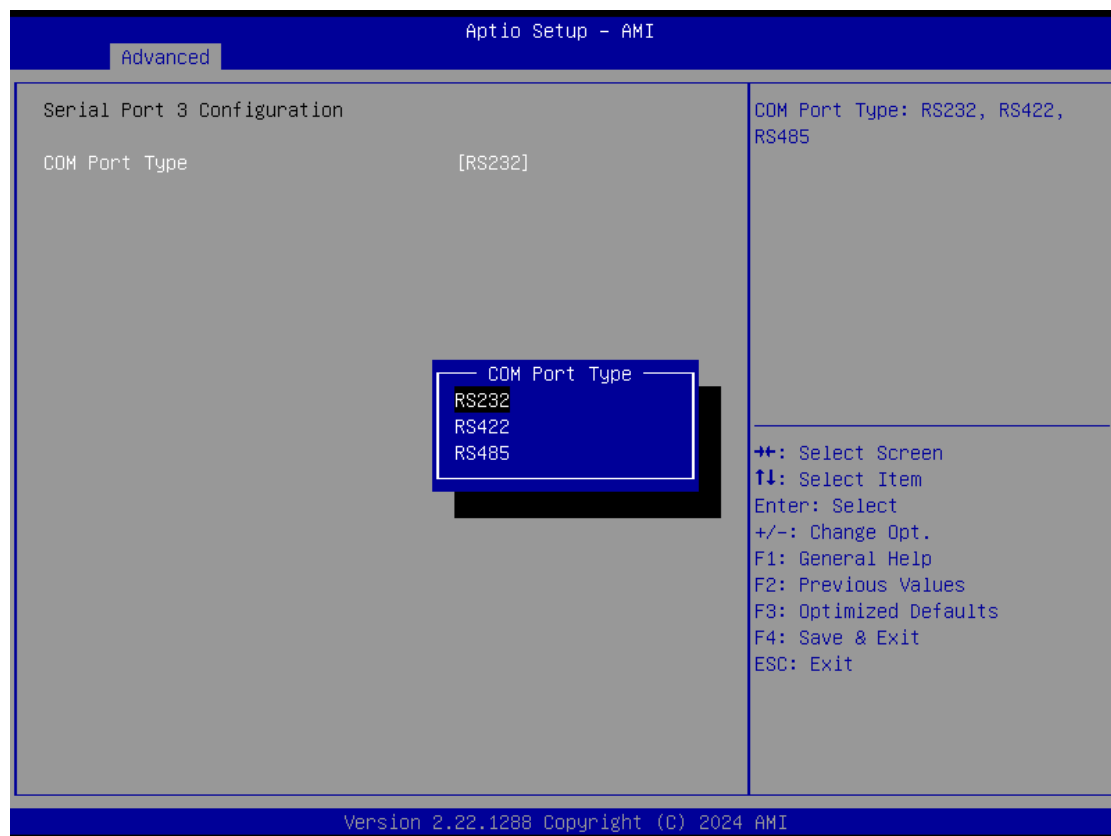
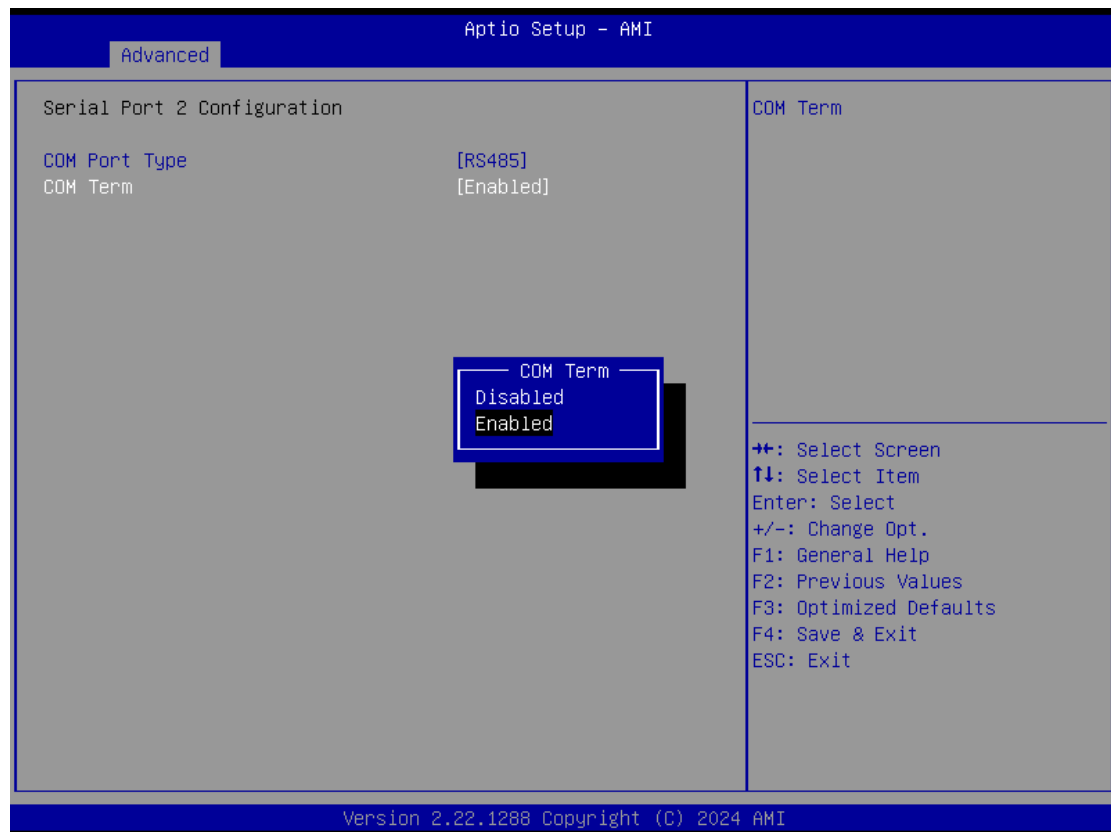

Aptio Setup - AMI

Advanced

Serial Port 3 Configuration

COM Port Type [RS422]
COM Term [Enabled]

COM Term

Disabled
Enabled

++: Select Screen
↑↓: Select Item
Enter: Select
+/-: Change Opt.
F1: General Help
F2: Previous Values
F3: Optimized Defaults
F4: Save & Exit
ESC: Exit

Version 2.22.1288 Copyright (C) 2024 AMI

Aptio Setup - AMI

Advanced

Serial Port 3 Configuration

COM Port Type [RS485]
COM Term [Enabled]

COM Term

Disabled
Enabled

++: Select Screen
↑↓: Select Item
Enter: Select
+/-: Change Opt.
F1: General Help
F2: Previous Values
F3: Optimized Defaults
F4: Save & Exit
ESC: Exit

Version 2.22.1288 Copyright (C) 2024 AMI

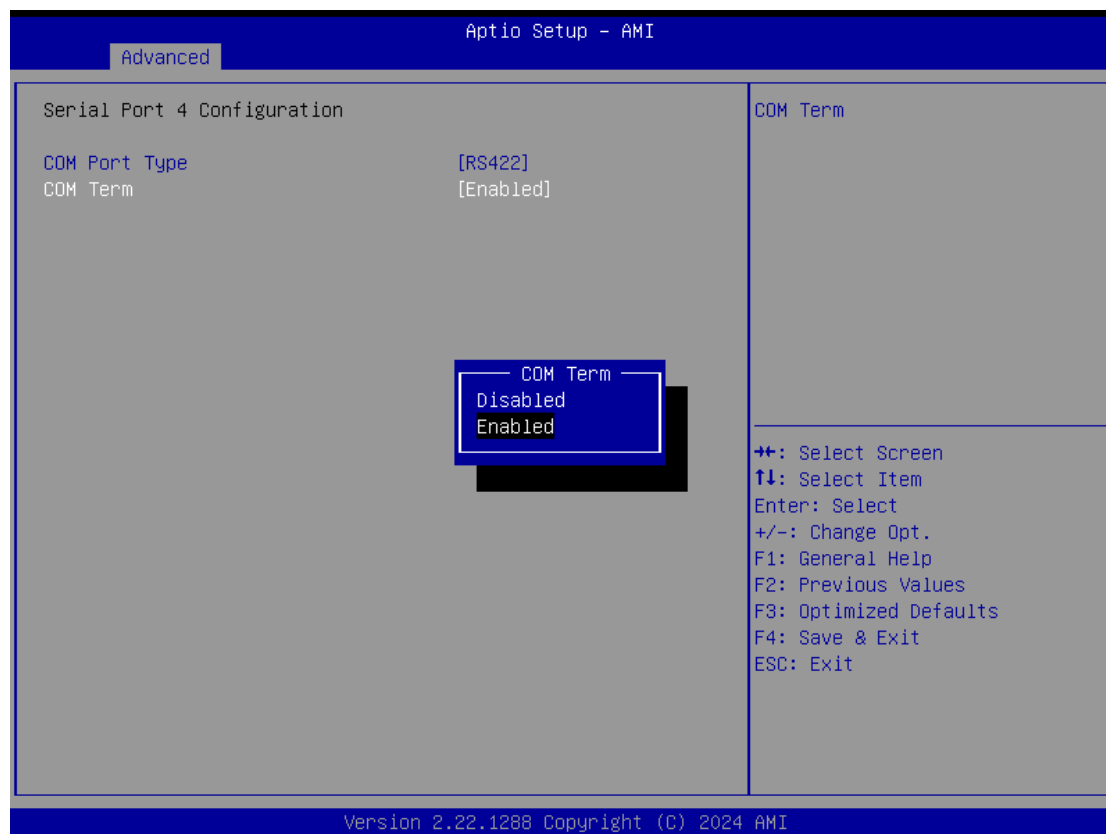
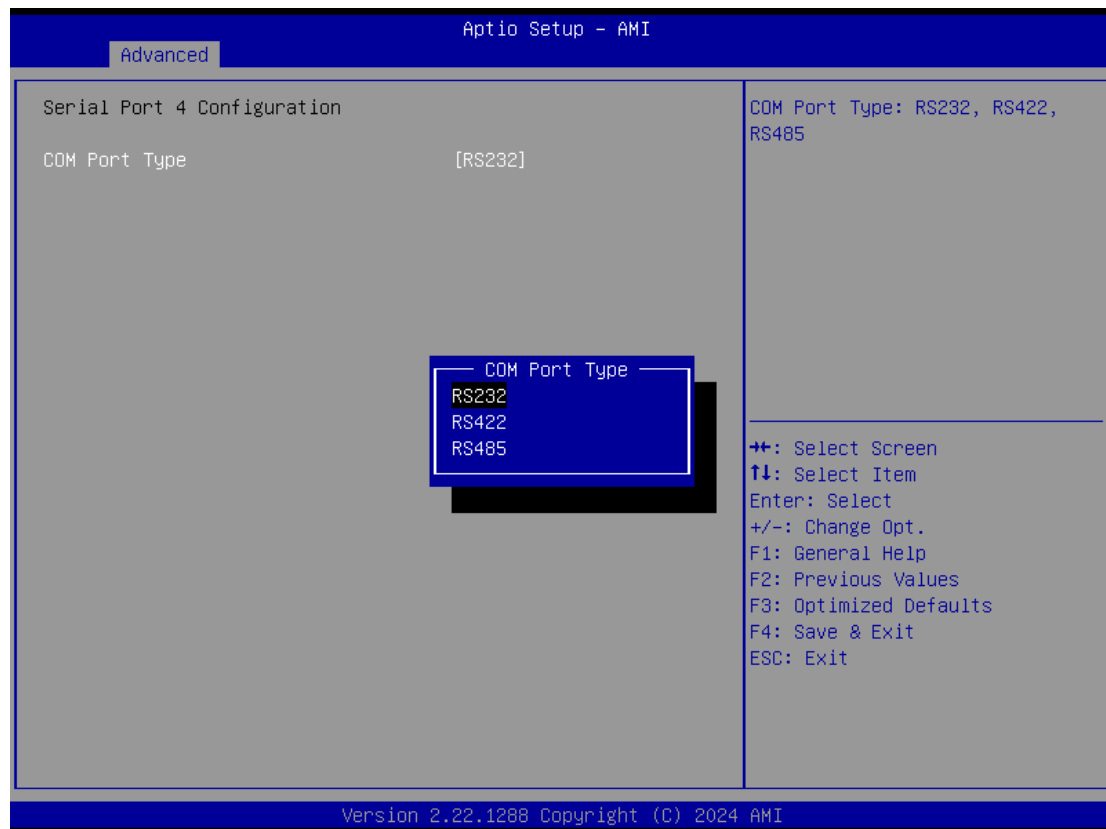

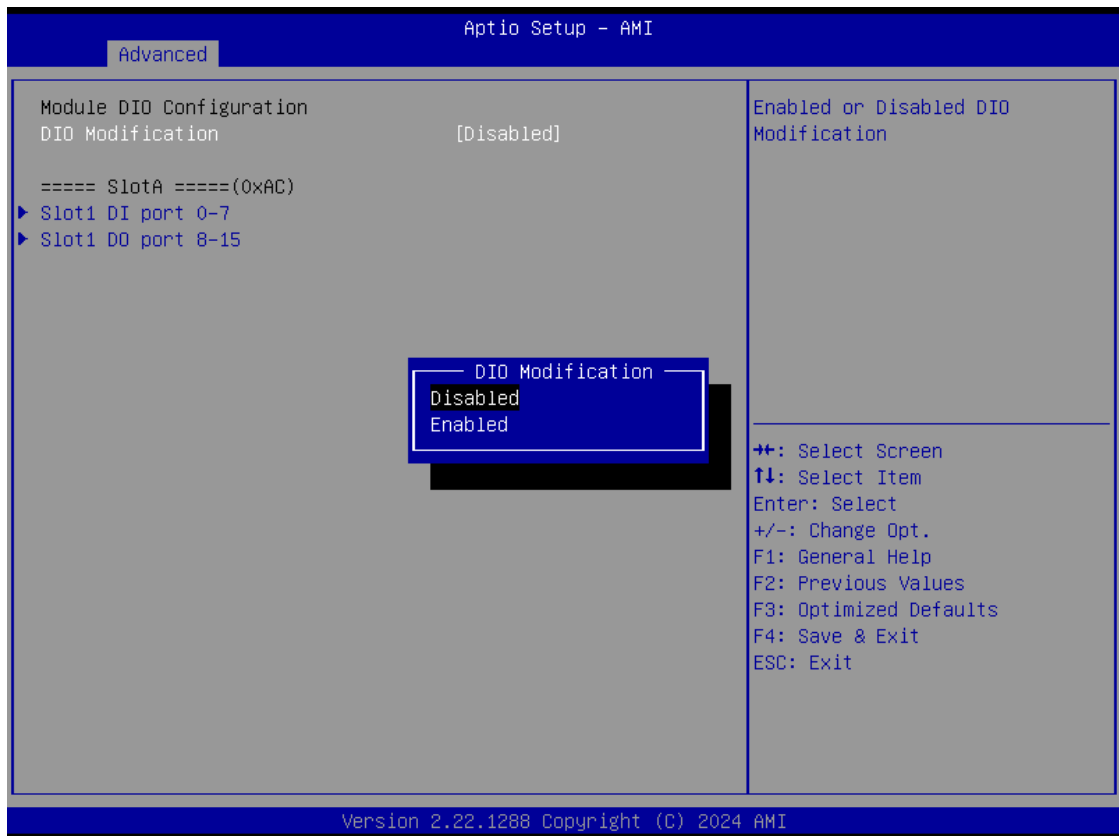
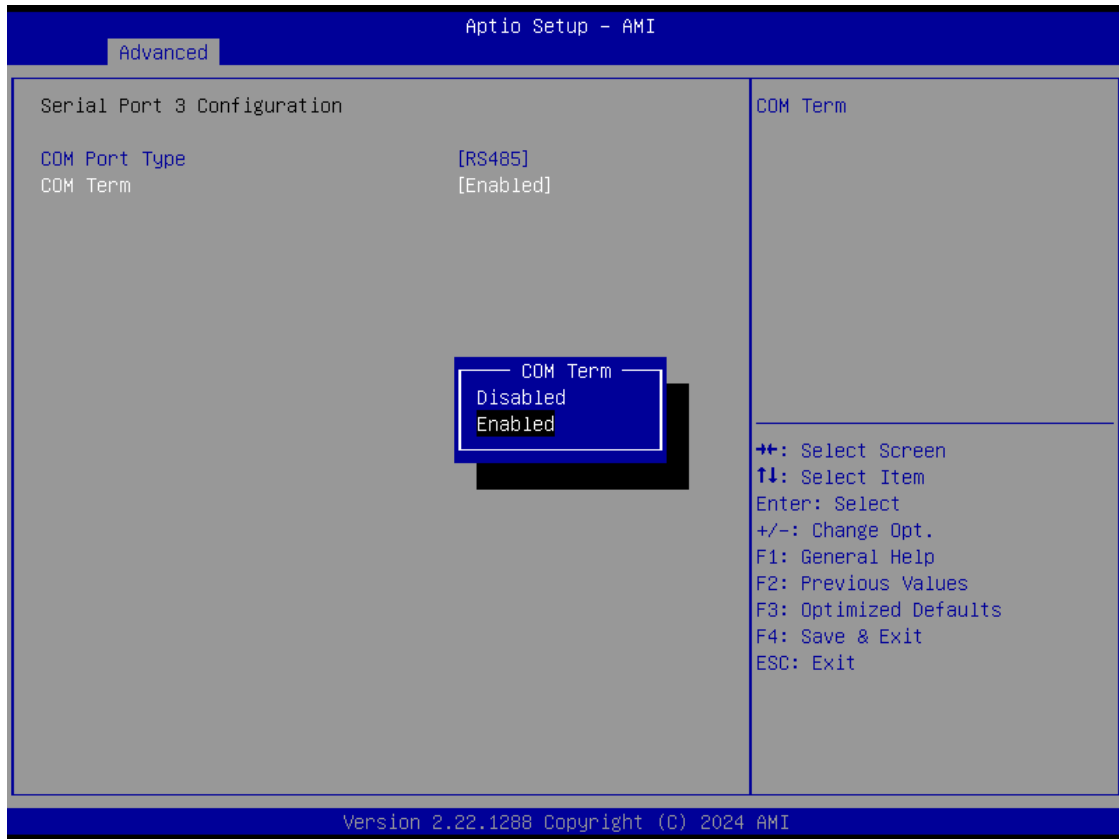

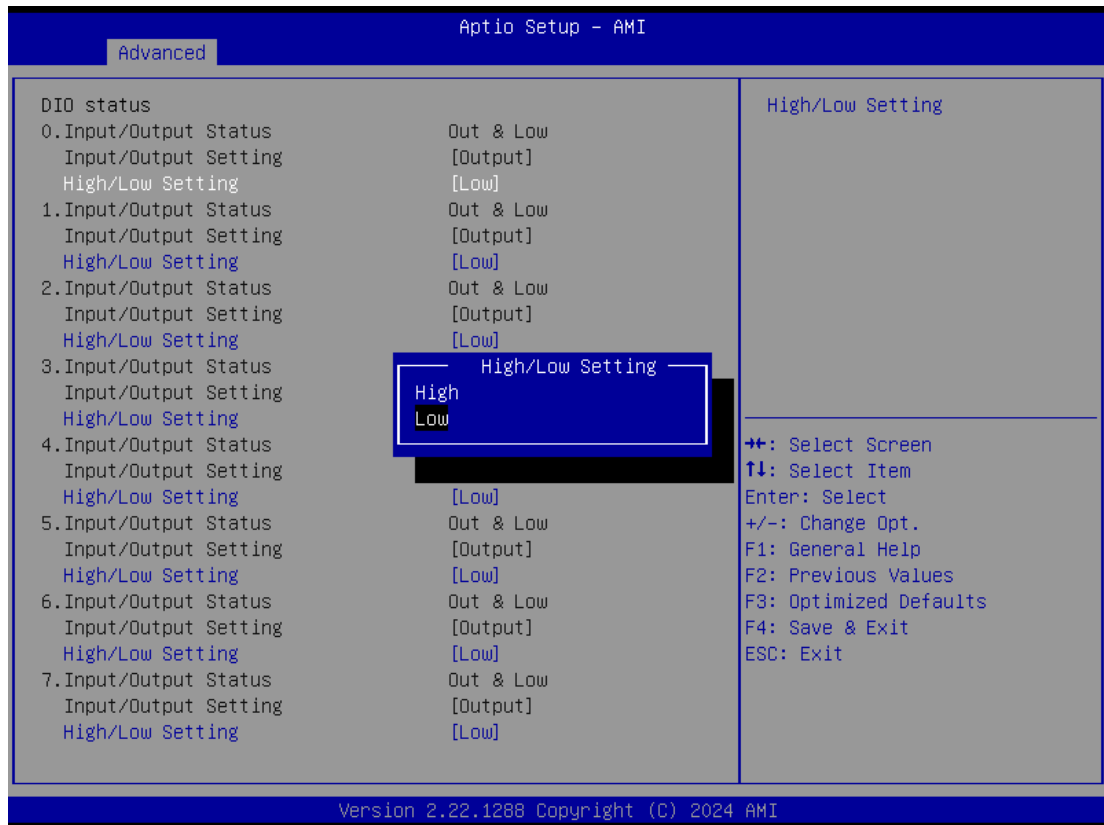
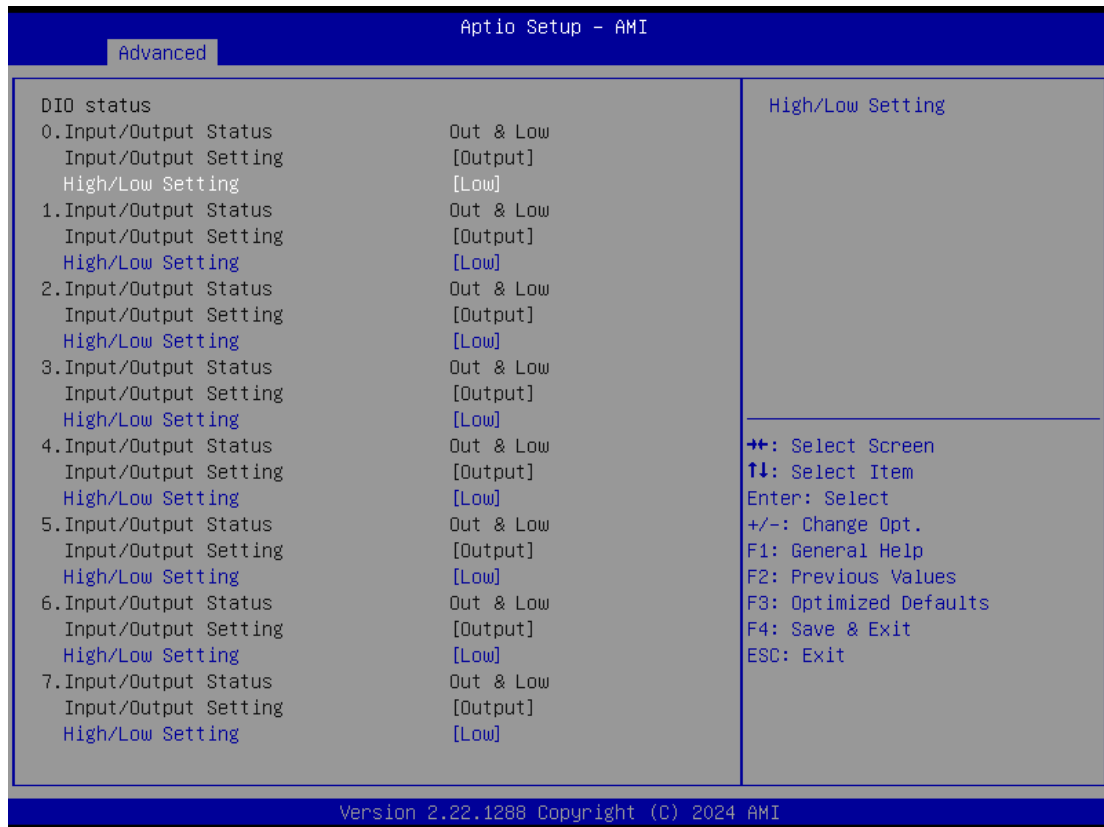

Advanced		Aptio Setup - AMI	
DIO status			
08.	Input/Output Status	In & High	
	Input/Output Setting	[Input]	
09.	Input/Output Status	In & High	
	Input/Output Setting	[Input]	
10.	Input/Output Status	In & High	
	Input/Output Setting	[Input]	
11.	Input/Output Status	In & High	
	Input/Output Setting	[Input]	
12.	Input/Output Status	In & High	
	Input/Output Setting	[Input]	
13.	Input/Output Status	In & High	
	Input/Output Setting	[Input]	
14.	Input/Output Status	In & High	
	Input/Output Setting	[Input]	
15.	Input/Output Status	In & High	
	Input/Output Setting	[Input]	
			⇐: Select Screen ↑↓: Select Item Enter: Select +/-: Change Opt. F1: General Help F2: Previous Values F3: Optimized Defaults F4: Save & Exit ESC: Exit
Version 2.22.1288 Copyright (C) 2024 AMI			

3.4 Chipset Feature

The Chipset menu allows users to change the advanced chipset settings. Users can select any of the items in the left frame of the screen to go to the sub menus:

System Agent (SA) Configuration

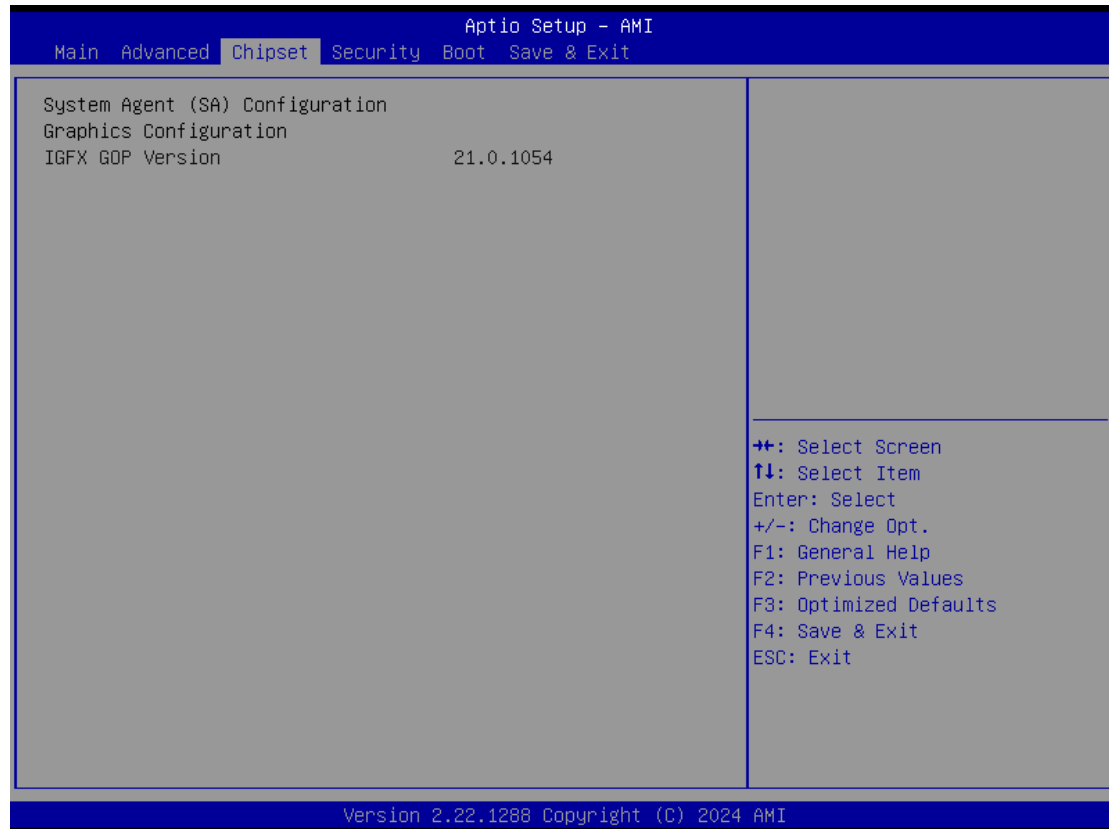

3.5 Security

The Security menu allows users to set an administrator password and a user password to enhance system security. No password is set in the default setting.

(Please refer below graphics.)

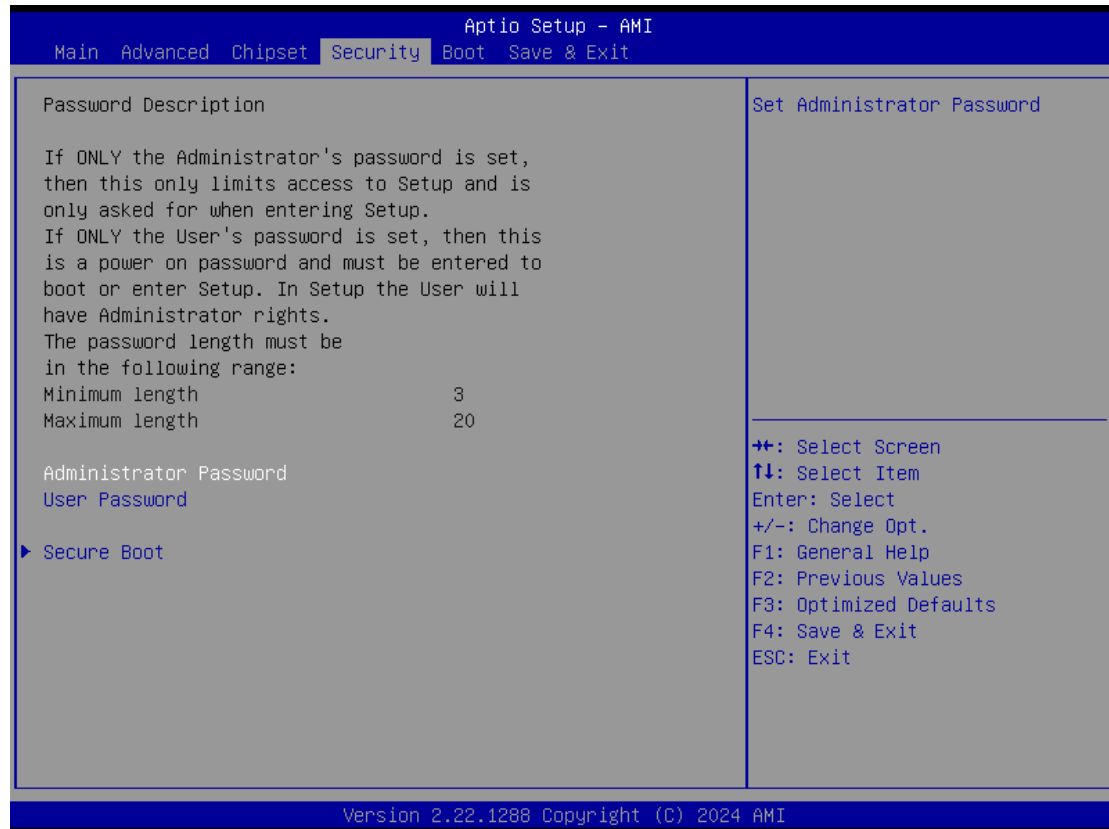

Administrator Password

This item indicates whether an administrator password has been set (installed or uninstalled).

User Password

This item indicates whether a user password has been set (installed or uninstalled).



Note: The BIOS default has no password. The user must remember the password after creating it. If the user forgets the password the RMA is the only solution.

● **Secure Boot**



Secure Boot

Secure Boot feature is Active if Secure Boot is Enabled, Platform Key (PK) is enrolled and the System is in User mode. The mode change requires platform reset. Secure Boot ensures that the system only boots from trusted software, preventing malicious software from loading and compromising the device. It checks the digital signatures of boot loaders, firmware, and operating systems to verify that they are from trusted sources and have not been tampered with. Users can choose to enable it or not, between standard and custom mode.



Secure Boot Mode

Secure Boot mode options: Standard or Custom. In Custom mode, Secure Boot Policy variables can be configured by a physically present user without full authentication.

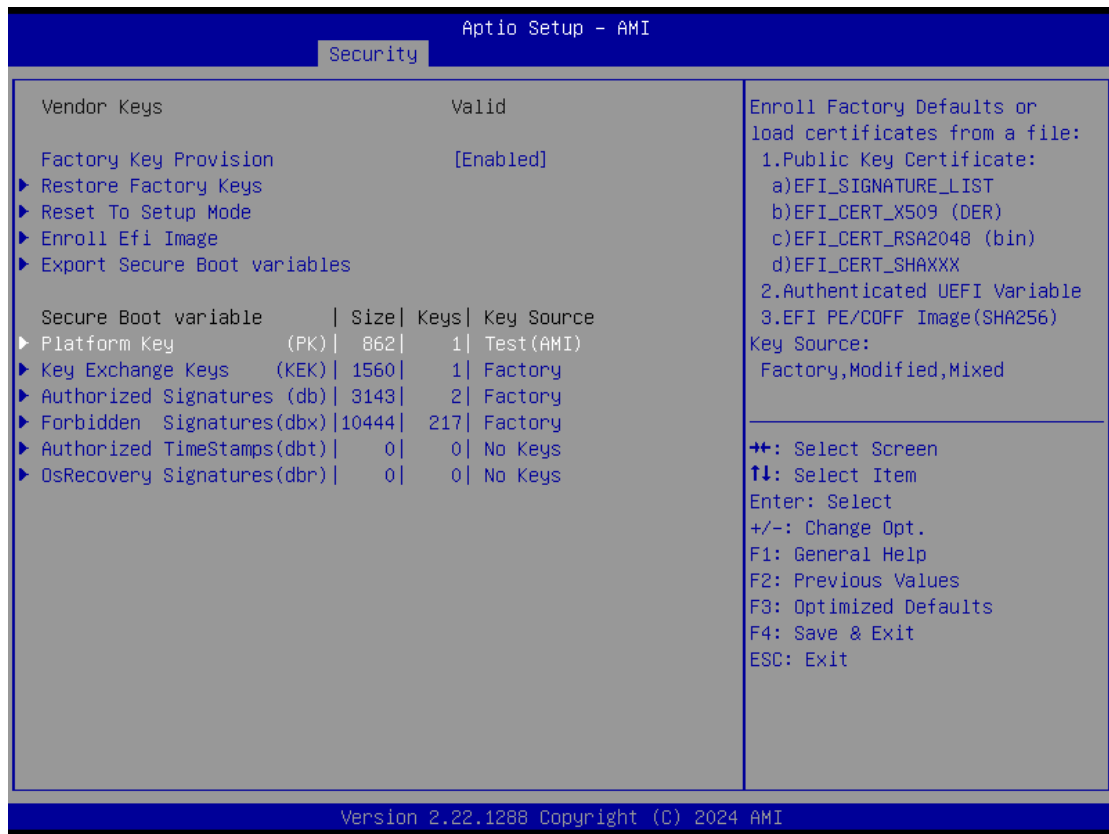
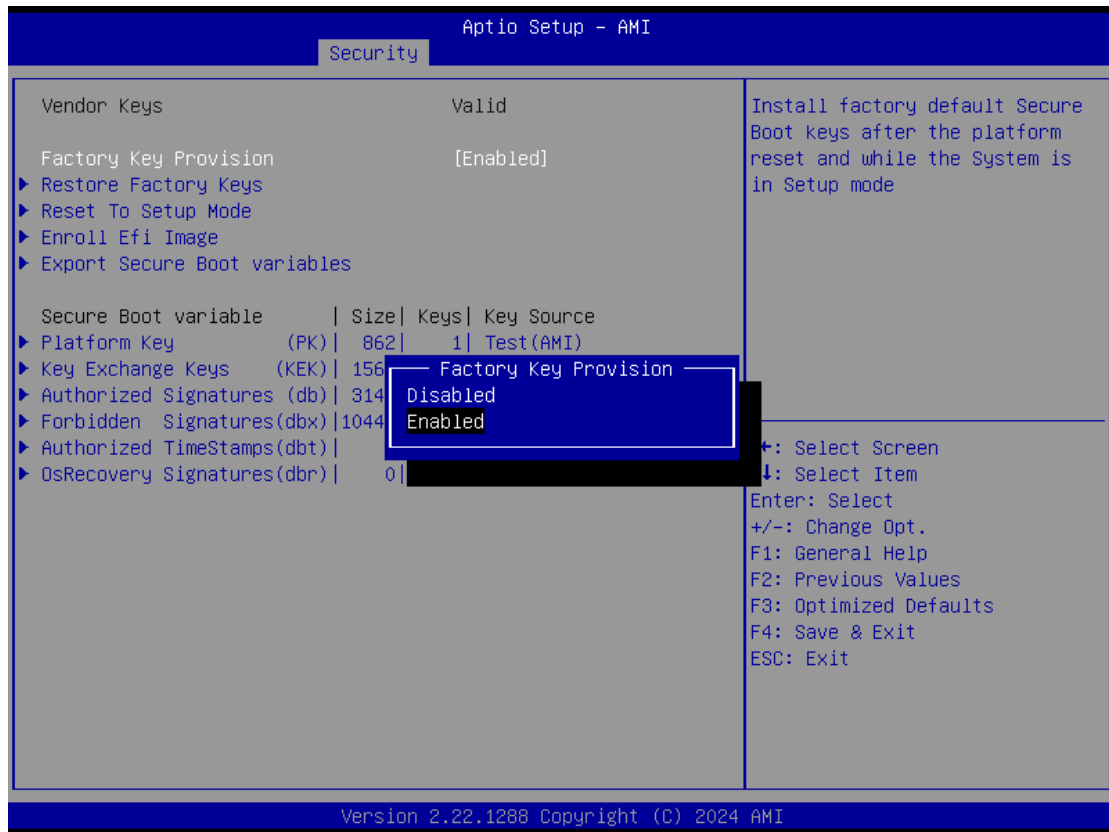

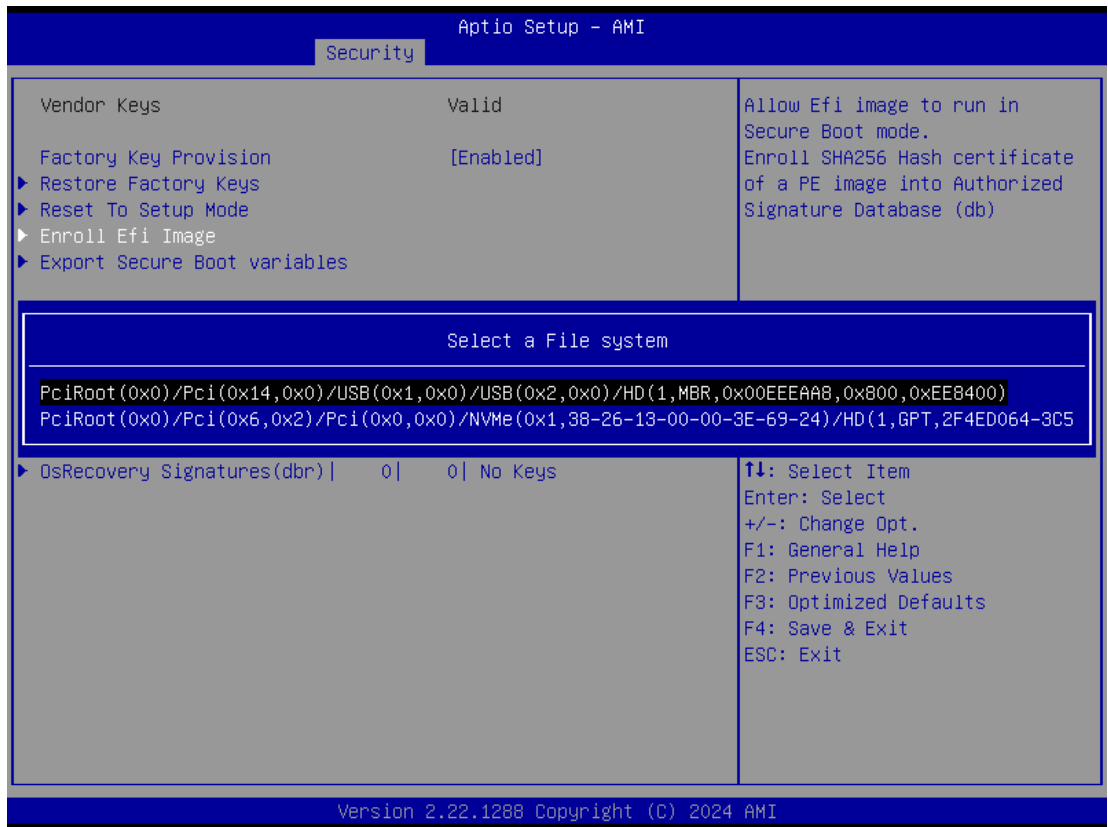
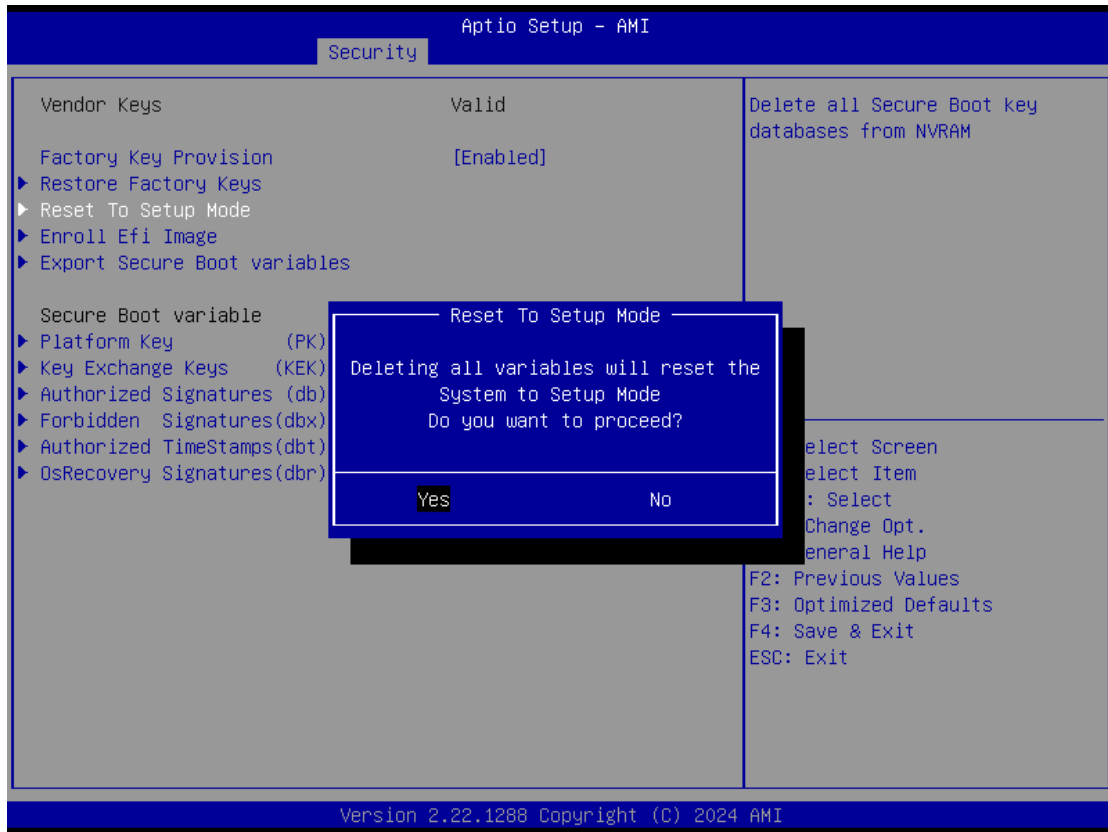

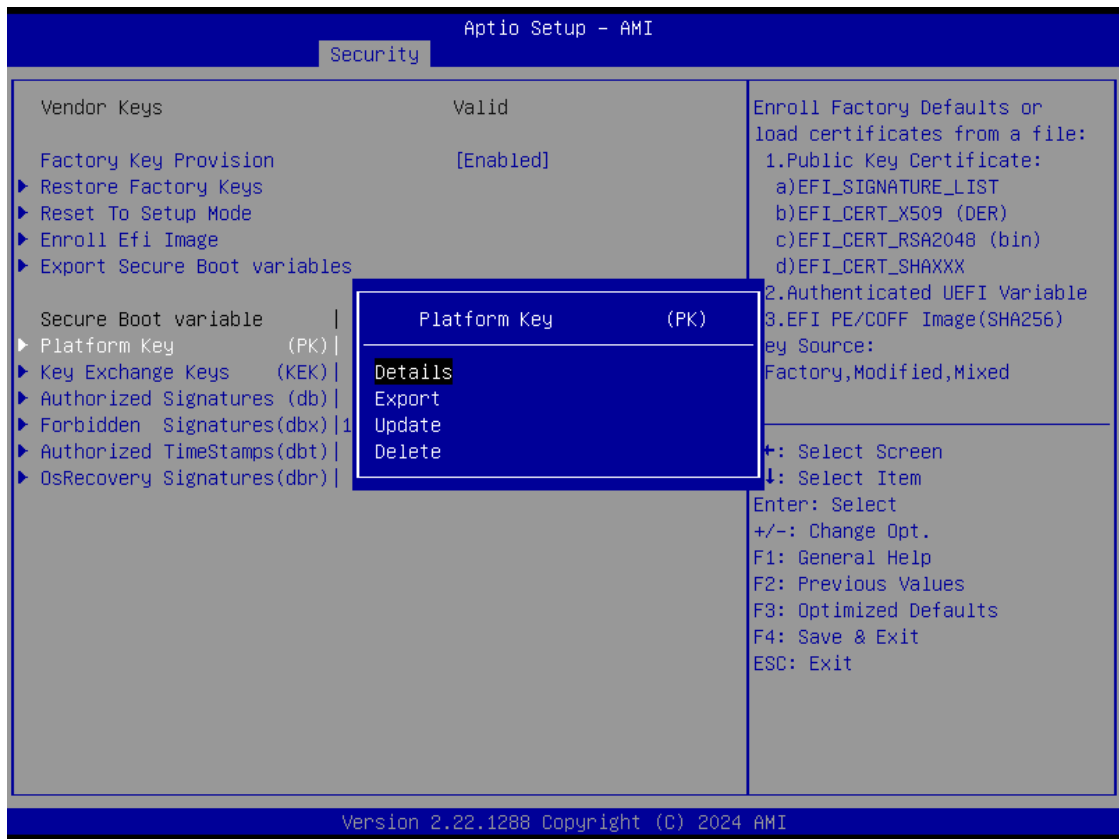
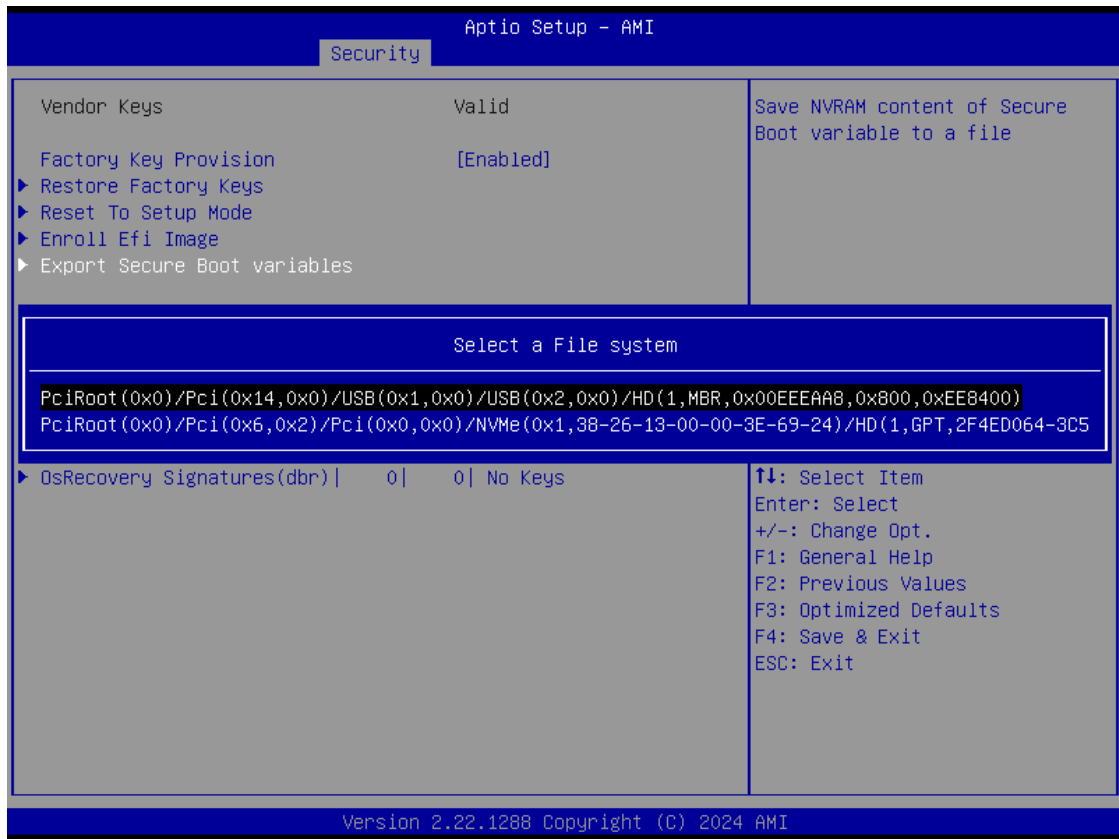

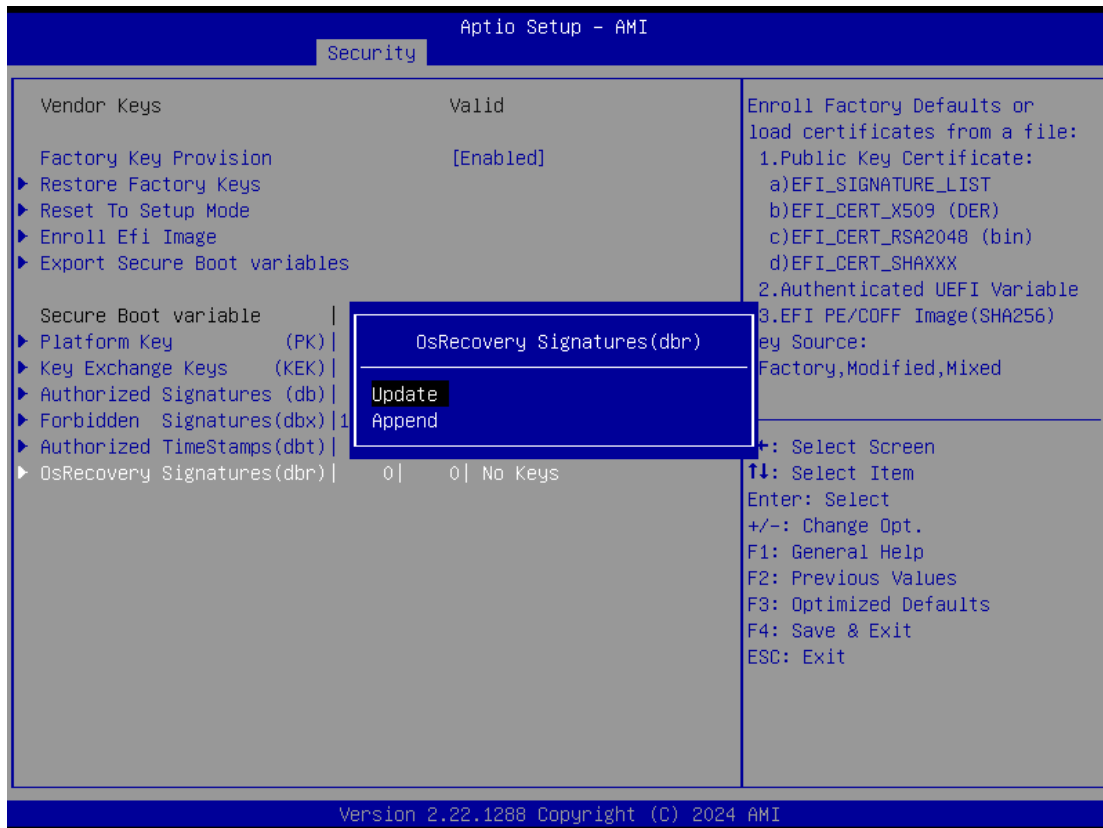
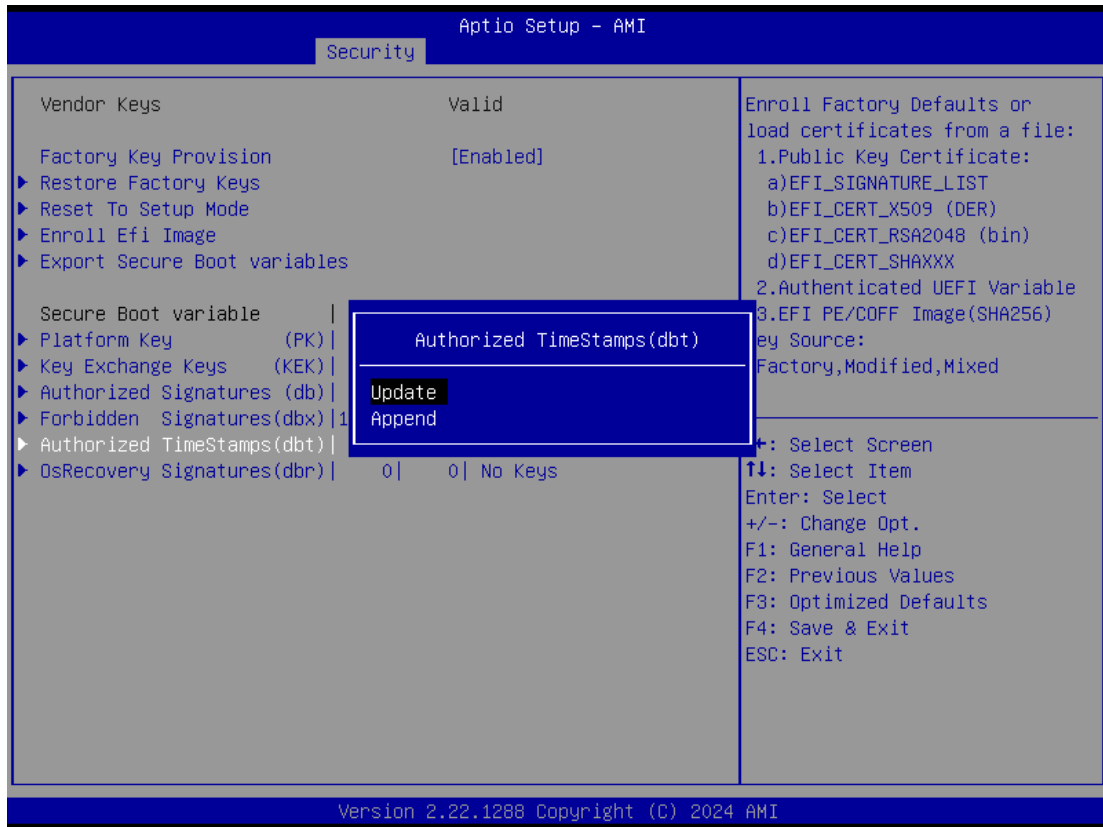

The Factory Key Provision

The Factory Key Provision ensures that the device has secure access to encrypted resources, such as data storage or communication. The keys are often unique to each device and can be used to secure firmware updates, secure boot processes, and to encrypt data at rest. The factory key provisioning process is an important step in securing devices and maintaining the confidentiality of sensitive information.

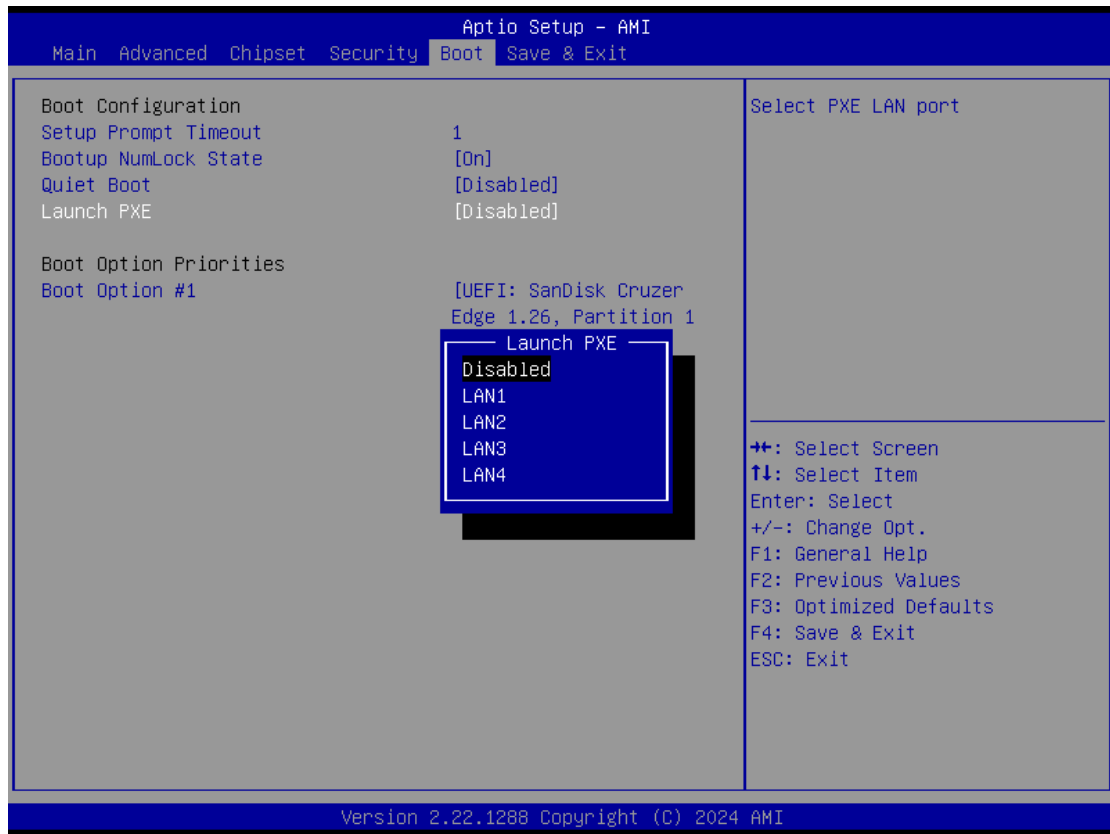

Setup Prompt Timeout

Use this item to set up number of seconds to wait for setup activation key where 65535(0xFFFF) means indefinite waiting.

Bootup NumLock State

Use this item to select the power-on state for the keyboard NumLock.

Boot Option Priorities

These are settings for boot priority. Specify the boot device priority sequence from the available devices.

3.7 Save & Exit

The Save & Exit menu allows users to load system configurations with optimal or fail-safe default values.

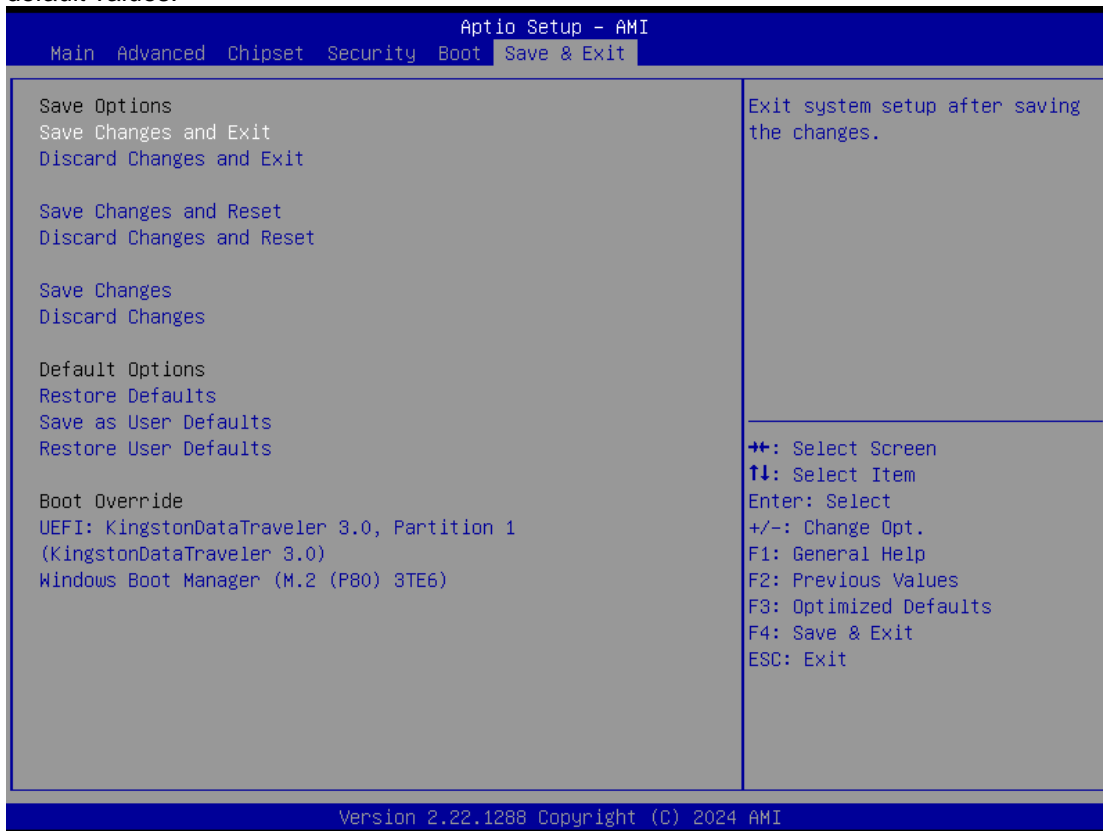

Save Changes and Exit

When users have completed the system configuration changes, select this option to leave Setup and return to Main Menu. Select Save Changes and Exit from the Save & Exit menu and press <Enter>. Select Yes to save changes and exit.

Discard Changes and Exit

Select this option to quit Setup without making any permanent changes to the system configurations and return to Main Menu. Select Discard Changes and Exit from the Save & Exit menu and press <Enter>. Select Yes to discard changes and exit.

Save Changes and Reset

After completing the system configuration changes, select this option to leave Setup and reboot the computer so the new system configurations will take effect. Select Save Changes and Reset from the Save & Exit menu and press <Enter>. Select Yes to save changes and reset.

Discard Changes and Reset

Select this option to quit Setup without making any permanent changes to the system configuration and reboot the computer. Select Discard Changes and Reset from the Save & Exit menu and press <Enter>. Select Yes to discard changes and reset.

Save Changes

After completing the system configuration changes, select this option to save changes. Select Save Changes from the Save & Exit menu and press <Enter>. Select Yes to save changes.

Discard Changes

Select this option to quit Setup without making any permanent changes to the system configurations. Select Discard Changes from the Save & Exit menu and press <Enter>. Select Yes to discard changes.

Restore Defaults

It automatically sets all Setup options to a complete set of default settings when users select this option. Select Restore Defaults from the Save & Exit menu and press <Enter>.

Save as User Defaults

Select this option to save system configuration changes done so far as User Defaults. Select Save as User Defaults from the Save & Exit menu and press <Enter>.

Restore User Defaults

It automatically sets all Setup options to a complete set of User Defaults when users select this option. Select Restore User Defaults from the Save & Exit menu and press <Enter>.

Boot Override

Select a drive to immediately boot that device regardless of the current boot order.

APPENDIX A WATCHDOG TIMER

About Watchdog Timer

After the system stops working for a while, it can be auto-reset by the watchdog timer. The integrated watchdog timer can be set up in the system reset mode by a program.

How to Use Watchdog Timer

The following example shows how to enable configuration using a debug tool.

Step	Description	Sample code	Note
1	Enter configuration mode	O 2E 87	Un-lock super I/O
		O 2E 87	
2	Select logic device	O 2E 07	Select logic register
		O 2F 07	Switch to WDT device
3	Set timer value	O 2E F6	Select logic register
		O 2F 05	Timer value 0~255 (Sec/Min) (Ex: 5)
4	Clear WDT status (optional)	O 2E F5	Select logic register
		O 2F 40	
5	Set time unit and start WDT	O 2E F5	Select logic register
		O 2F M	M = 28h (Minute) , M = 20h (Second)

This page is intentionally left blank.

APPENDIX B POWER BUTTON SETTING FOR WINDOWS

To change how the power button operates, go to the console of the PC and then follow below figures to complete the setting.

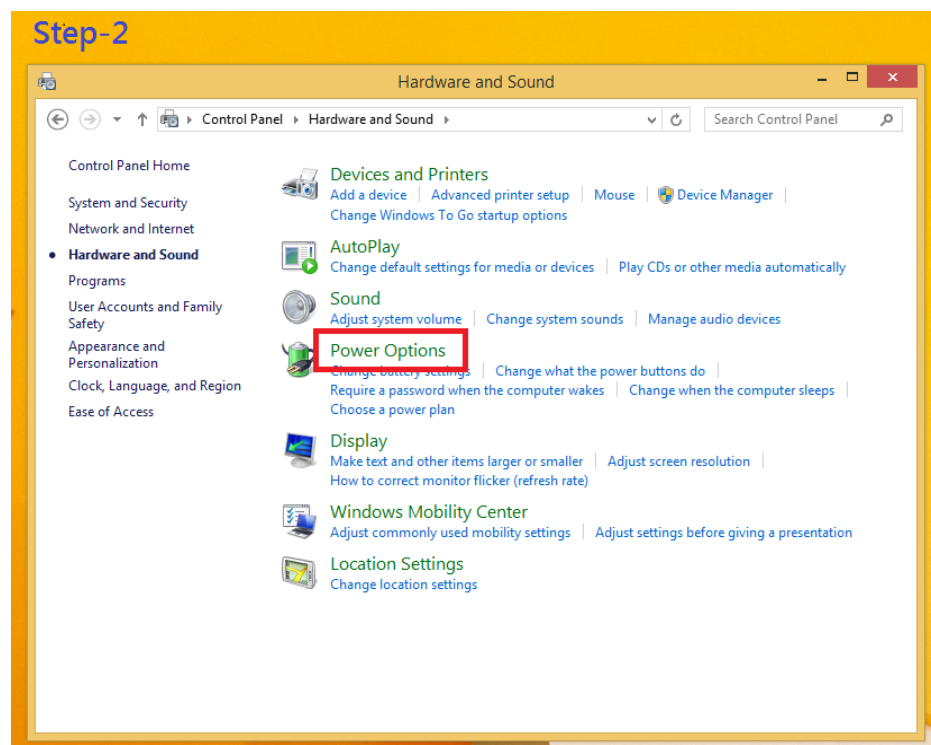
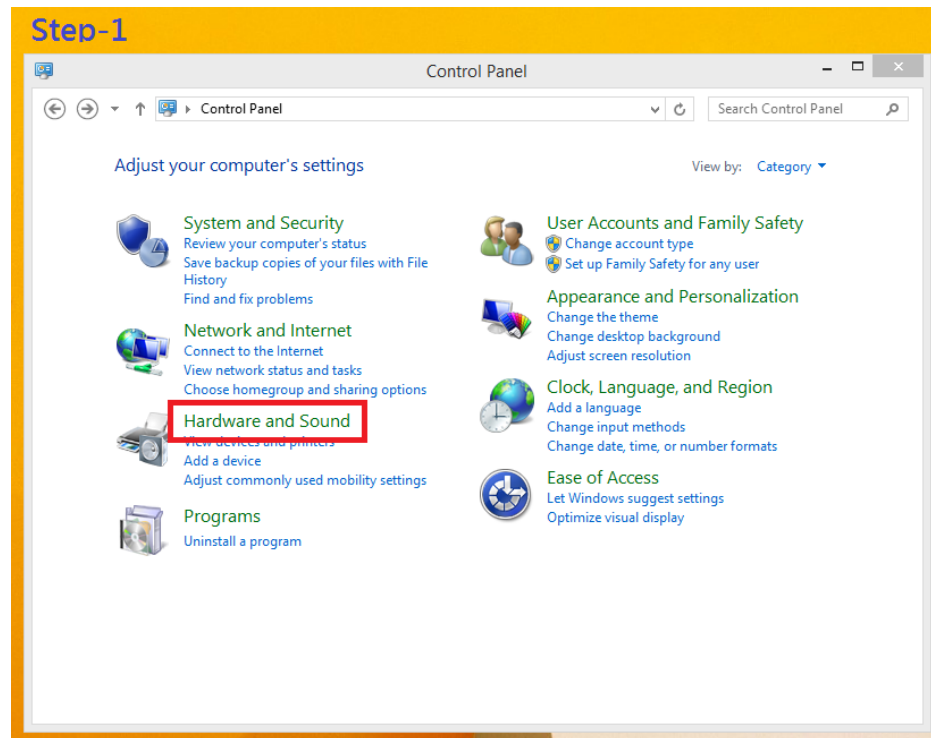

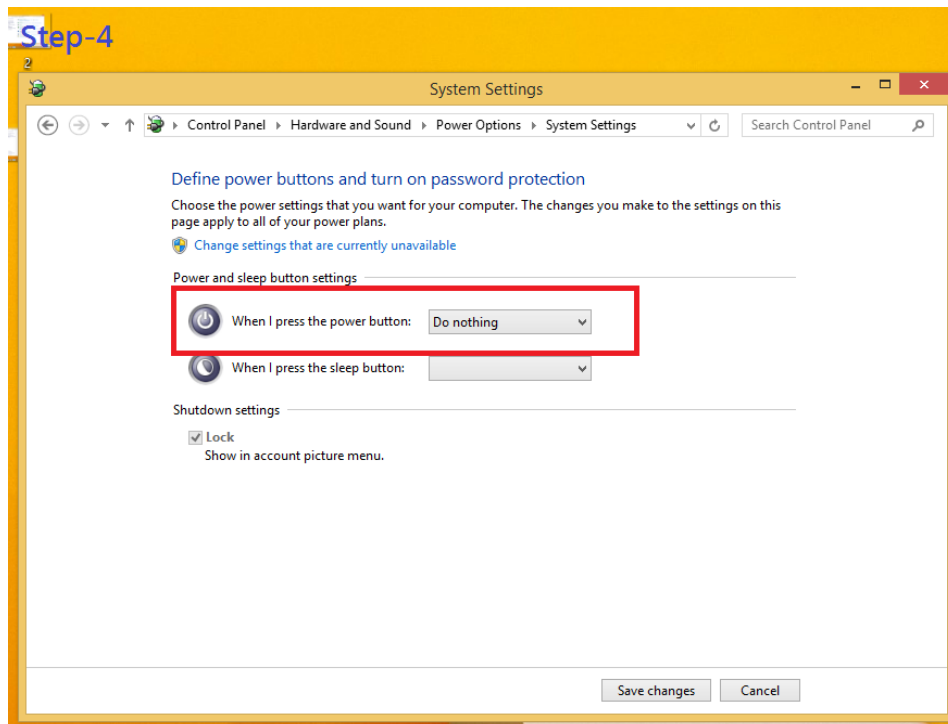
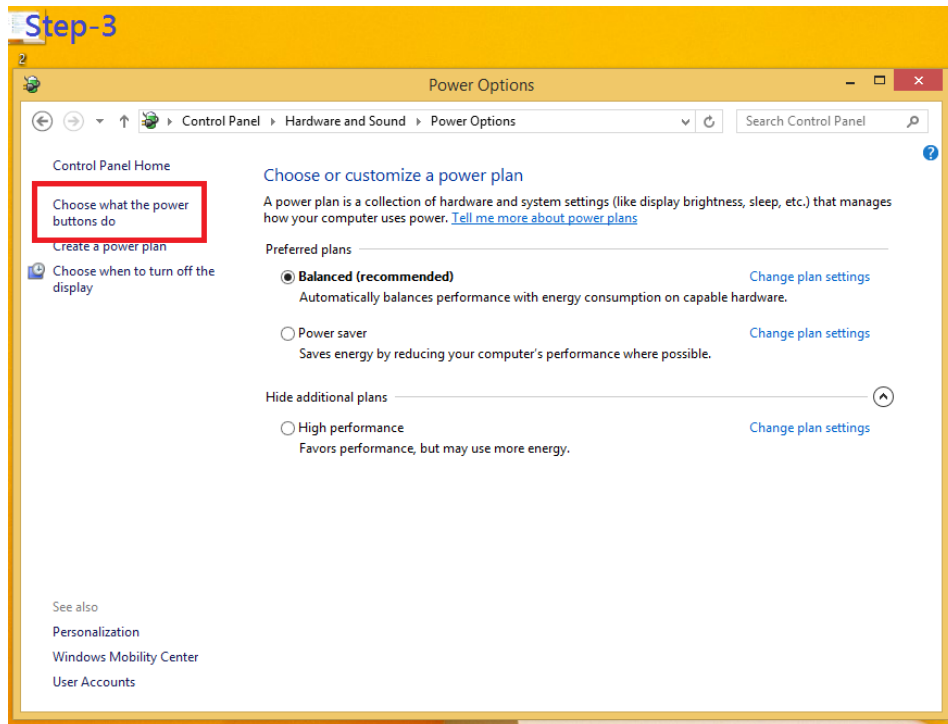

Step-5

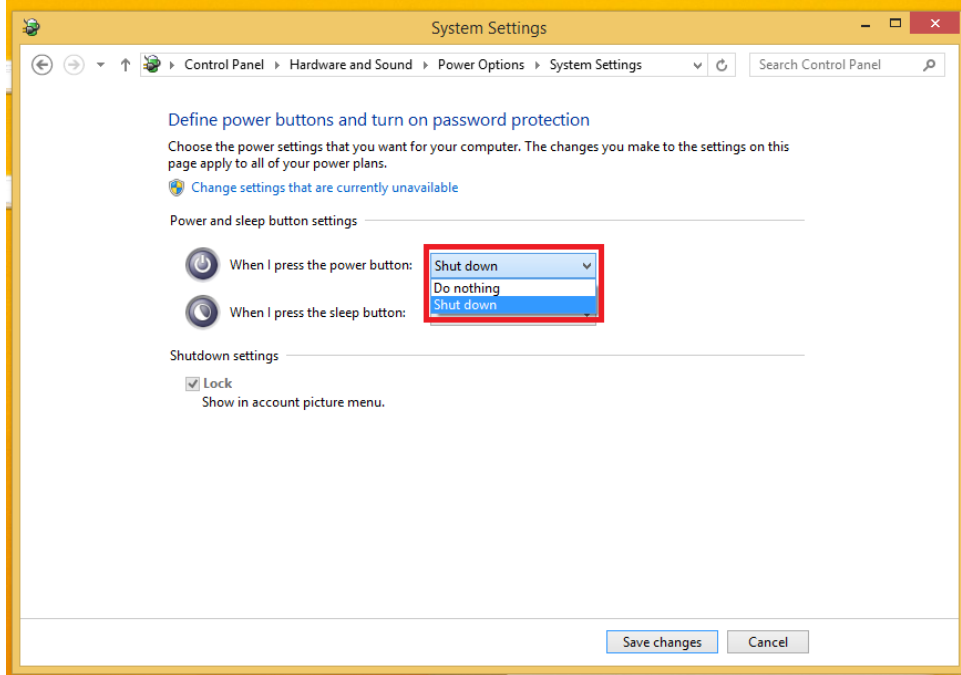

Step-6

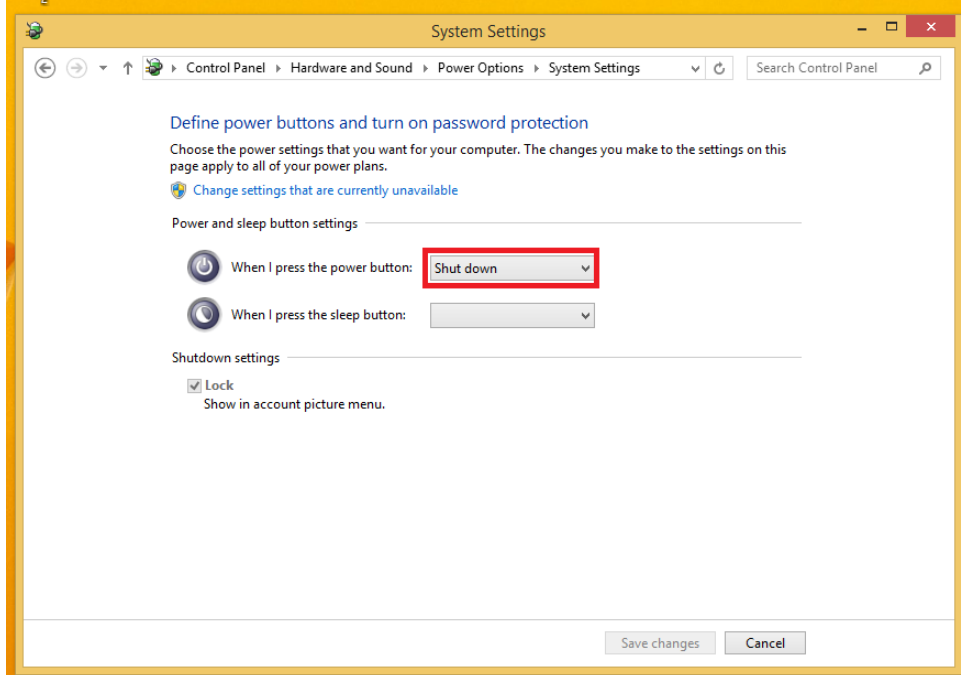

This page is intentionally left blank.

APPENDIX C DIGITAL I/O

Digital Input:

Ext Power Input Voltage: 30Vdc Max.

Digital Input channels: 4, sink/source type

Digital Input voltage: 0 to 30VDC

Input level for dry contacts:

Logic level 0: close

Logic level 1: open

Input level for wet contacts:

Logic level 1: +/-3VDC max.

Logic level 0: +/- 10VDC min. to +/-30VDC max. (source to digital input)

Digital output:

COM+ Power Input Voltage: 30Vdc Max. On-state voltage:12~ 24VDC nominal

Output channels: 4, sink type,

Output current: 200mA max. per channel

Digital I/O Software Programming

- I2C to GPIO PCA9554PW GPIO Group0[3:0] is Output, Group0[7:4] is Input.
- I2C address: 0100010x.
- Registers:

Table 3. Command byte

Command	Protocol	Function
0	read byte	Input Port register
1	read/write byte	Output Port register

Table 4. Register 0 - Input Port register bit description

Bit	Symbol	Access	Value	Description
7	I7	read only	X	determined by externally applied logic level
6	I6	read only	X	
5	I5	read only	X	
4	I4	read only	X	
3	I3	read only	X	
2	I2	read only	X	
1	I1	read only	X	
0	I0	read only	X	

Table 5. Register 1 - Output Port register bit description

Legend: * default value.

Bit	Symbol	Access	Value	Description
7	O7	R	1*	reflects outgoing logic levels of pins defined as outputs by Register 3
6	O6	R	1*	
5	O5	R	1*	
4	O4	R	1*	
3	O3	R	1*	
2	O2	R	1*	
1	O1	R	1*	
0	O0	R	1*	

Digital Input Wiring

Dry Contact (1):

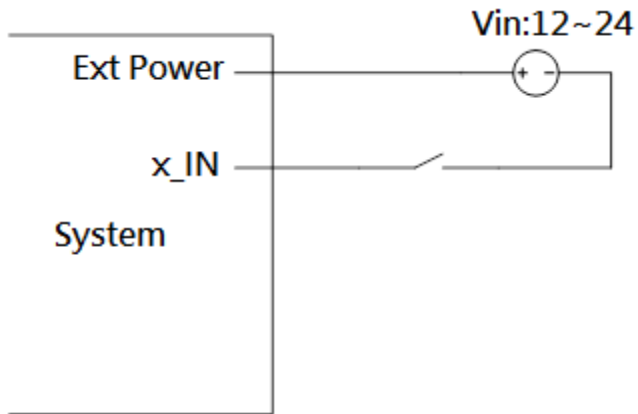

With external power.

Dry Contact (2):

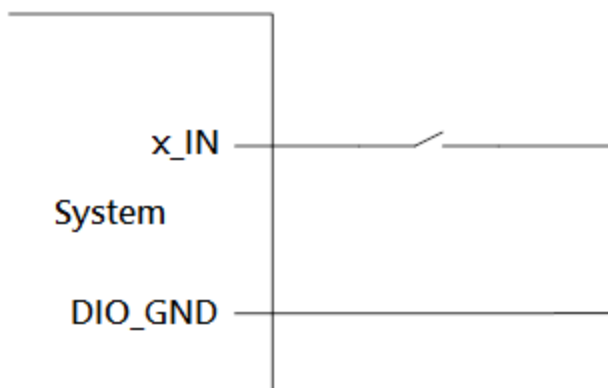

Without external power.

Wet Contact (1):

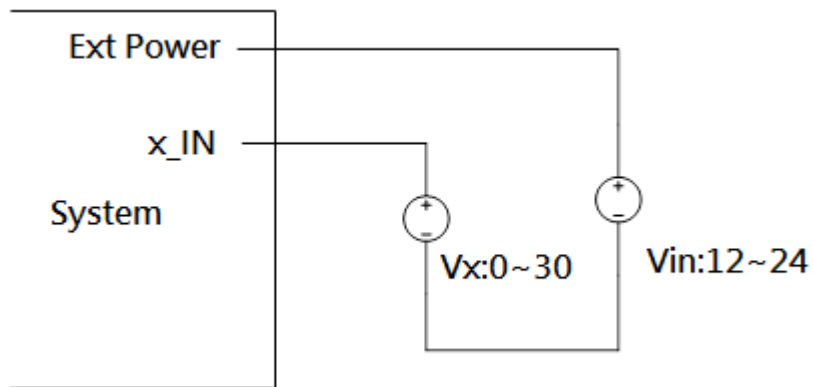

Wet Contact (2):

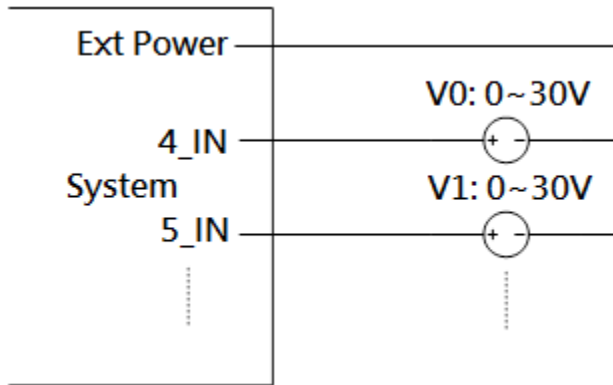

Digital Output Wiring

DO drive high: x_OUT equal to COM-(up to 200mA)

DO drive low: High impedance

