



AirLink MP70 Series

Hardware User Guide

Important Notice

Due to the nature of wireless communications, transmission and reception of data can never be guaranteed. Data may be delayed, corrupted (i.e., have errors) or be totally lost. Although significant delays or losses of data are rare when wireless devices such as the Sierra Wireless modem are used in a normal manner with a well-constructed network, the Sierra Wireless modem should not be used in situations where failure to transmit or receive data could result in damage of any kind to the user or any other party, including but not limited to personal injury, death, or loss of property. Sierra Wireless accepts no responsibility for damages of any kind resulting from delays or errors in data transmitted or received using the Sierra Wireless modem, or for failure of the Sierra Wireless modem to transmit or receive such data.

Safety and Hazards

Do not operate the Sierra Wireless modem in areas where blasting is in progress, near medical equipment, near life support equipment, or any equipment which may be susceptible to any form of radio interference. In such areas, the Sierra Wireless modem **MUST BE POWERED OFF**. The Sierra Wireless modem can transmit signals that could interfere with this equipment.

The driver or operator of any vehicle should not operate the Sierra Wireless modem while in control of a vehicle. Doing so will detract from the driver or operator's control and operation of that vehicle. In some states and provinces, operating such communications devices while in control of a vehicle is an offence.

Warning: *EXPLOSION HAZARD—DO NOT DISCONNECT WHILE CIRCUIT IS LIVE UNLESS THE AREA IS KNOWN TO BE NON-HAZARDOUS.*

Avertissement: *RISQUE D'EXPLOSION—NE PAS DEBRANCHER TANT QUE LE CIRCUIT EST SOUS TENSION, A MOINS QU'IL NE S'AGISSE D'UN EMPLACEMENT NON DANGEREUX.*

Warning: *DO NOT USE THE USB CONNECTOR IN A HAZARDOUS AREA.*

Avertissement: *NE PAS UTILISER DE CONNECTEUR USB DANS LES ENVIRONNEMENTS DANGEREUX.*

Warning: *DO NOT USE THE RESET BUTTON IN A HAZARDOUS AREA.*

Avertissement: *NE PAS UTILISER LE BOUTON DE RESET DANS UN ENVIRONNEMENT DANGEREUX.*

Limitation of Liability

The information in this manual is subject to change without notice and does not represent a commitment on the part of Sierra Wireless. SIERRA WIRELESS AND ITS AFFILIATES SPECIFICALLY DISCLAIM LIABILITY FOR ANY AND ALL DIRECT, INDIRECT, SPECIAL, GENERAL, INCIDENTAL, CONSEQUENTIAL, PUNITIVE OR EXEMPLARY DAMAGES INCLUDING, BUT NOT LIMITED TO, LOSS OF PROFITS OR REVENUE OR ANTICIPATED PROFITS OR REVENUE ARISING OUT OF THE USE OR INABILITY TO USE ANY SIERRA WIRELESS PRODUCT, EVEN IF SIERRA WIRELESS AND/OR ITS AFFILIATES HAS BEEN ADVISED OF THE POSSIBILITY OF SUCH DAMAGES OR THEY ARE FORESEEABLE OR FOR CLAIMS BY ANY THIRD PARTY.

Notwithstanding the foregoing, in no event shall Sierra Wireless and/or its affiliates aggregate liability arising under or in connection with the Sierra Wireless product, regardless of the number of events, occurrences, or claims giving rise to liability, be in excess of the price paid by the purchaser for the Sierra Wireless product.

Patents

This product may contain technology developed by or for Sierra Wireless Inc. This product includes technology licensed from QUALCOMM®. This product is manufactured or sold by Sierra Wireless Inc. or its affiliates under one or more patents licensed from MMP Portfolio Licensing.

Third Party License

THIRD PARTY SOFTWARE LICENSE TERMS

THIS SIERRA WIRELESS PRODUCT MAY CONTAIN THIRD PARTY SOFTWARE PROVIDED BY INVENSENSE, INC. BY USING THE INVENSENSE POSITIONING LIBRARY (THE "SOFTWARE"), YOU ARE AGREEING TO BE BOUND BY THE FOLLOWING TERMS. Subject to the following terms and conditions, InvenSense grants to you a non-exclusive license to use the Software solely for the purpose (the "Purpose") of running the Software on the Sierra Wireless device in which it is embedded (the "Device"). The Software, including all intellectual property rights therein, is and will remain the sole and exclusive property of InvenSense. You may not (i) distribute the Software separately from the Device, (ii) modify the Software; (iii) copy the Software; (iv) reverse engineer the Software; or (v) use the Software other than for the Purpose.

Disclaimer. TO THE MAXIMUM EXTENT PERMITTED BY APPLICABLE LAW, INVENSENSE MAKES NO WARRANTY OF ANY KIND, EXPRESS OR IMPLIED, WITH REGARD TO THE SOFTWARE, INCLUDING, BUT NOT LIMITED TO, INFRINGEMENT AND THE IMPLIED WARRANTIES OF MERCHANTABILITY AND FITNESS FOR A PARTICULAR PURPOSE. IN NO EVENT WILL INVENSENSE OR ITS SUPPLIERS, RESELLERS, OR DISTRIBUTORS BE LIABLE FOR ANY LOST REVENUE, PROFIT, OR DATA, OR FOR SPECIAL, INDIRECT, CONSEQUENTIAL, INCIDENTAL, OR PUNITIVE DAMAGES HOWEVER CAUSED AND REGARDLESS OF THE THEORY OF LIABILITY, ARISING OUT OF THE USE OF OR INABILITY TO USE THE SOFTWARE EVEN IF INVENSENSE OR ITS SUPPLIERS, RESELLERS, OR DISTRIBUTORS HAVE BEEN ADVISED OF THE POSSIBILITY OF SUCH DAMAGES. IN NO EVENT SHALL INVENSENSE'S OR ITS SUPPLIERS; RESELLERS; OR DISTRIBUTORS' TOTAL LIABILITY TO YOU, WHETHER IN CONTRACT, TORT (INCLUDING NEGLIGENCE), OR OTHERWISE, EXCEED ONE HUNDRED UNITED STATES DOLLARS (US \$100) IN THE AGGREGATE. THE FOREGOING LIMITATIONS SHALL APPLY EVEN IF THE ABOVE-STATED WARRANTY FAILS OF ITS ESSENTIAL PURPOSE. BECAUSE SOME STATES OR JURISDICTIONS DO NOT ALLOW LIMITATION OR EXCLUSION OF CONSEQUENTIAL OR INCIDENTAL DAMAGES, THE ABOVE LIMITATION MAY NOT APPLY TO YOU.

Copyright © 2024 Sierra Wireless. All rights reserved.

Trademarks Sierra Wireless®, AirPrime®, AirLink®, AirVantage® and the Sierra Wireless logo are registered trademarks of Sierra Wireless.

Windows® and Windows Vista® are registered trademarks of Microsoft Corporation.

Macintosh® and Mac OS X® are registered trademarks of Apple Inc., registered in the U.S. and other countries.

QUALCOMM® is a registered trademark of QUALCOMM Incorporated. Used under license.

Other trademarks are the property of their respective owners.

Contact Information

Sales information and technical support, including warranty and returns	Web: sierrawireless.com/company/contact-us/ Global toll-August 2024free number: 1-877-687-7795 6:00 am to 5:00 pm PST
Corporate and product information	Web: sierrawireless.com

Contents

Introduction to the MP70 Series	8
Key Features	8
Description	9
Modes and Power Consumption	10
Accessories	10
Warranty	10
Installation and Startup	11
Tools and Materials Required	11
Installation Overview	11
Step 1 — Insert the SIM Cards	12
Step 2 — Mount and Ground the MP70 Chassis	12
Orientation	13
Grounding	13
Cabling Concerns	13
Cable Strain Relief	14
Step 3 — Connect the Antennas	14
Recommended Antenna Separation	15
Step 4 — Connect the Data Cables	15
Step 5 — Connect the Power	16
Fusing	16
DC Voltage Transients	16
Power Connector on the MP70	17
Connect the Router to the Vehicle’s Electrical System	17
Wiring Diagrams	18
Step 6 (Optional) — Connect the Vehicle Bus Cable	20
Dead Reckoning Calibration	21
I/O Configuration	21
I/O Pins	22
Step 7 — Check the Router Operation	28
LED Behavior	29
Ethernet LEDs	30

Step 8—Configure the Software	30
Reboot the MP70.....	32
Reset the MP70 to Factory Default Settings.....	32
Recovery Mode.....	32
Specifications	34
Certification and Interoperability.....	34
Reliability	34
Environmental Testing.....	35
Included Radio Module Firmware	36
Network Technology.....	36
Host Interfaces.....	37
SIM Card Interface	38
Input/Output.....	39
Power Adapter Pins.....	39
Reset	39
LEDs.....	39
Screw Torque Settings.....	39
Operating Voltage	39
Power Specifications	40
GNSS Technology.....	40
Protocols.....	40
Wi-Fi Performance	41
Wi-Fi Output Power	41
Wi-Fi Channels Supported.....	42
Radio Frequency Bands	43
GNSS Bands supported	57
Carrier Aggregation Combinations	57
Mechanical Specifications	64

Regulatory Information	65
Important Information for North American Users	65
RF Exposure	65
EU	67
Accessories	69
DC Power Cable (Black Connector)	69
AC Power Adapter (Black Connector).....	70
AC Power Adapter Input	70
AC Power Adapter Output	70
AC Power Adapter Environmental Specifications	71
AC Power Adapter Reliability and Quality Control	71
AC Power Adapter Safety Standards	71
AC Power Adapter EMC Standards	72
AC Power Adapter Hazardous Substances	72
AC Power Adapter Energy Efficiency	72
Vehicle Bus Cables.....	72
I/O Cable.....	74
Index	75

1: Introduction to the MP70 Series

This hardware user guide is for the Sierra Wireless® AirLink® MP70 Series routers. Features and specifications described in this user guide apply to all MP70 Series routers unless otherwise noted.

The AirLink MP70 Series routers are high performance, LTE Advanced vehicle routers developed specifically for mobile mission-critical applications in public safety, transit, and field services.

Offering high power, long range Gigabit Wi-Fi and Gigabit Ethernet, and up to 600 Mbps downlink speed over LTE Advanced Pro, the AirLink MP70 Series routers unite the enterprise network with the fleet and enable applications to work simultaneously, further and faster from the vehicle area network (VAN) than ever before.

The AirLink MP70 Series routers support advanced remote visibility and instant insight into the vehicle area network (VAN), in-field applications and assets, and mobile workforces. Purpose built for vehicle and rail applications, the AirLink MP70 Series routers deliver superior reliability and uninterrupted operation in harsh mobile environments.

Key Features

- LTE Advanced Pro, with fallback to 3G HSPA+
- FirstNet support (Band 14) with Carrier Aggregation
- CBRS support (Band 48)
- 2.4/5 GHz Wi-Fi
- 4 Gigabit Ethernet ports
- 5 configurable GPIOs
- Direct vehicle bus interface (OBD-II/J1939)
- Inertial Navigation (Dead Reckoning)
- Built-in 9-axis accelerometer for driver behavior and motion sensing.

For information on configuring these features, refer to the ALEOS 4.9.0 (or later) Software Configuration User Guide for AirLink MP70.

Description

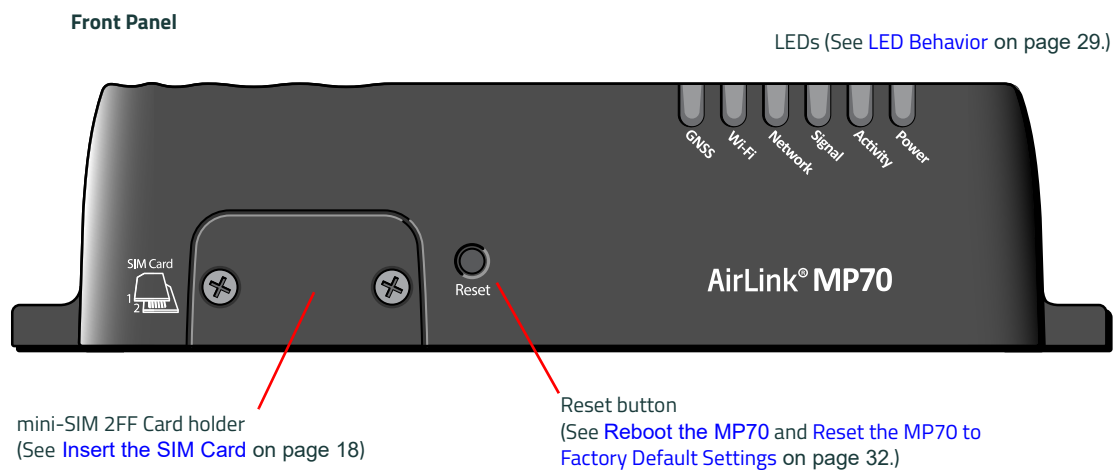
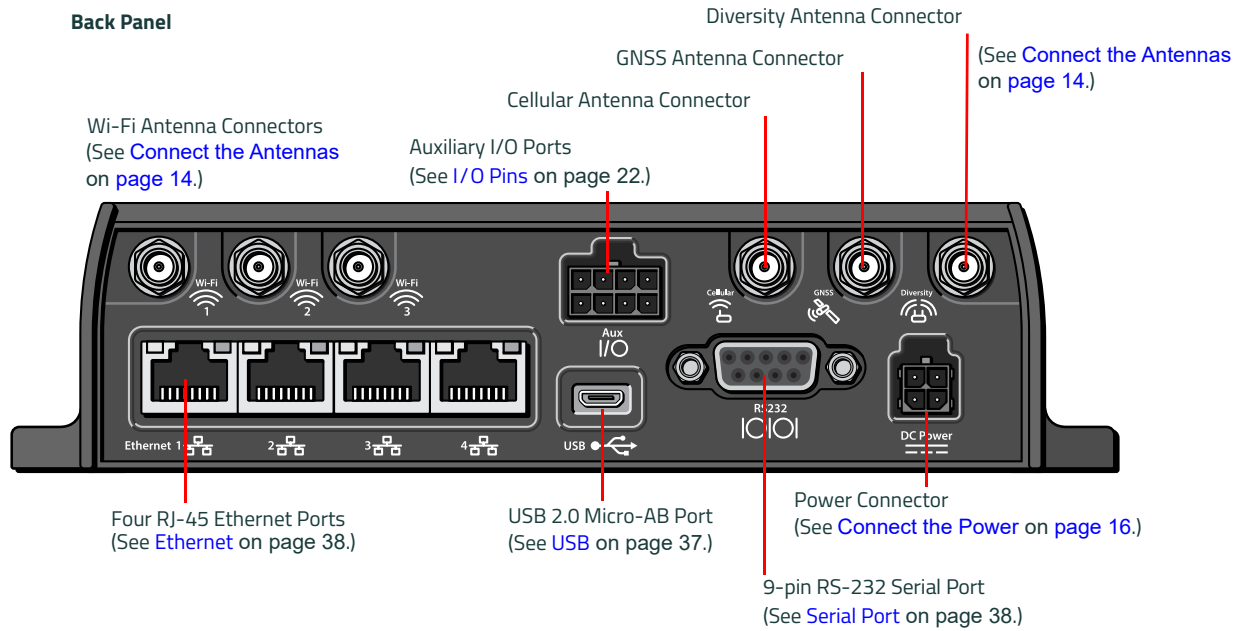

Figure 1-1: MP70 Connectors, LEDs and SIM Card Holder

Modes and Power Consumption

Table 1-1: Power Consumption Scenarios

Mode	Scenario	Power Consumption ^a
Off ^b	Ignition Off	17.28 mW (1.4 mA)
Standby ^c	Standby Mode	42.05 mW (3.5 mA)
On ^d	Typical Idle (No Wi-Fi)	2370 mW (197.24 mA)
	Typical Idle (Wi-Fi)	3730 mW (310.44 mA)
	Maximum	15,000 mW (1250 mA)
	Inrush Current	1.5 A @ 12 V (Averaged over 100 μ s)

- Power consumption was measured at 12 V.
- All power is switched off. Ignition is low, but V_{in} remains connected.
- The CPU and the radio are off, but the router can be woken by an I / O input voltage level or at a configured time.
- The CPU and the radio are on. When the router is idle (i.e. no traffic is being sent or received).

Accessories

The following items come with the MP70 router:

- DC power cable
- Mounting screws
- Quick Start Guide

The following items can be ordered separately from Sierra Wireless:

- Universal AC power adapter
 - Voltage input: 100 – 240 VAC
 - Current output: 1.5 A
 - Part number: 2000579
- I/O Auxiliary cable
 - Part number: 6001004
- OBD-II Y-cable
 - Part number: 6001204
- J1939 Y-cable
 - Part number: 6001192

Warranty

You can download the MP70 router warranty from [the Sierra Wireless Source](#). Click **sign up** to register for free.

2: Installation and Startup

This chapter shows how to connect, install and start the Sierra Wireless MP70. It also describes the front panel LEDs, and I/O functionality.

Note: Sierra Wireless recommends that a professional vehicle electronics installer perform the installation. An experienced installer typically completes a standard installation in approximately half an hour.

Tools and Materials Required

- Power supply — AC or DC (DC power cable is supplied by Sierra Wireless)
- A SIM card (provided by your mobile network operator)
- #1 Phillips screwdriver
- Laptop computer with Ethernet cable
- LTE MIMO antennas — Main and Diversity
- Optional:
 - GNSS antenna
 - MIMO Wi-Fi antennas¹
 - 9-pin connection cable for the RS-232 port
 - 8-pin auxiliary I/O connector cable
 - OBD-II or J1939 vehicle bus cable

Caution: *The router has a hardened case for use in industrial environments and vehicles. If you are installing it in these types of environments, use cables designed and specified for use in these types of environment to avoid cable failure.*

Installation Overview

The steps for a typical installation are:

1. Insert the SIM card(s) — [page 12](#).
2. Mount and ground the MP70 chassis — [page 12](#).
3. Connect the antennas — [page 14](#).
4. Connect the data cables — [page 15](#).
5. Connect the power — [page 16](#).
6. Connect the vehicle bus cable (optional) — [page 20](#).
7. Check the router operation — [page 28](#).
8. Configure the software — [page 30](#).

The following sections describe these steps in detail. Read these sections carefully before performing the installation.

1. Applies only to the MP70 Wi-Fi model

Note: Depending on where you are installing the MP70, you may want to mount the router before connecting the antenna, cables and power.

Step 1 — Insert the SIM Cards

The AirLink MP70 has two mini-SIM (2FF) card slots. The upper slot is Slot 1 and the lower slot is Slot 2. By default, the SIM card in Slot 1 is the Primary SIM card. If you are using only one SIM card, Sierra Wireless recommends that you install it in Slot 1.

If the SIM card (or SIM cards) have not already been installed, insert the SIM cards into the router before connecting any external equipment or power to the router.

To install the SIM cards:

1. Use a #1 Phillips screwdriver to remove the SIM card cover.
2. Orient the SIM card(s), as shown in [Figure 2-1](#). The gold contacts on the upper SIM card face down, and the gold contacts on the lower SIM card face up. If you are using only one SIM card, insert it in the upper SIM slot (Slot 1).
3. Gently slide the SIM cards into the slots until they click into place.

To remove a SIM card, press the SIM card in, and release it. Gently grip the SIM card and pull it out.

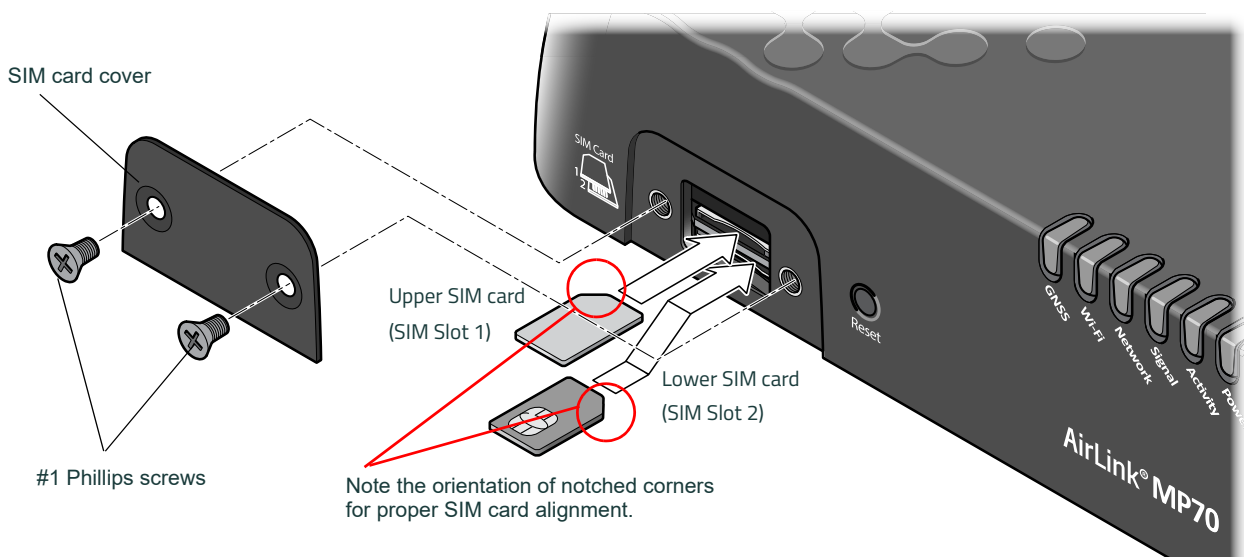

Figure 2-1: Installing the SIM Card

4. Replace the SIM card cover.

Step 2 — Mount and Ground the MP70 Chassis

The MP70 should not be mounted in the driver's area of the vehicle or in areas where it can distract the driver. Mount it in accordance with accepted after-market practices and materials.

Sierra Wireless strongly recommends that you always ground the chassis using the unpainted mounting hole shown in [Figure 2-2](#).

Mount the router where:

- There is easy access for attaching the cables
- Cables will not be constricted, close to high amperages or exposed to extreme temperatures
- The front panel LEDs are easily visible
- There is adequate airflow
- It is away from direct exposure to the elements, such as sun, rain, dust, etc.

The MP70 has 4 mounting holes, as shown in [Figure 2-2](#). Use the mounting screws that came with the MP70 to secure it in place.

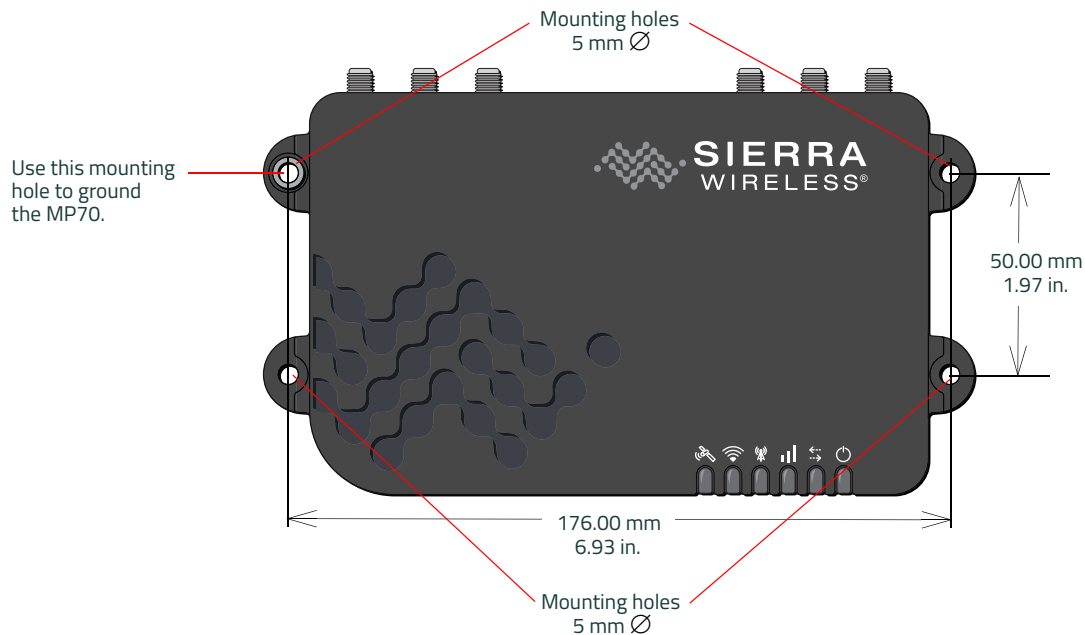

Figure 2-2: Mounting and Grounding the MP70

Orientation

For applications that use the dead reckoning/inertial navigation features of the MP70, ensure that the device is installed horizontally (flat) or oriented vertically at 90 degrees. Do not install the MP70 at an angle on a sloped or uneven surface. The recommended orientation will ensure that the MP70 inertial sensors will calibrate correctly.

Grounding

For DC installations (with a fixed “system” ground reference), Sierra Wireless recommends always grounding the MP70 chassis to this system ground reference.

To ensure a good grounding reference, either:

- Attach the MP70 to a grounded metallic surface.
- Connect one end of a short 18 AWG or larger gauge wire to the unpainted, upper right mounting hole (see [Figure 2-2](#)) and connect the other end to the vehicle chassis.

Cabling Concerns

Separate MP70 antenna, data, and power cables from other wiring in the vehicle and route away from sharp edges.

Cable Strain Relief

Sierra Wireless recommends using cable strain relief for installations in high-vibration environments.

Place the cable strain relief within 200 mm (8 in.) of the MP70 to reduce the mass of cable supported by the power connector under vibration. Ideally, the strain relief mounting for the DC cable should be attached to the same object as the MP70, so both the router and cable vibrate together. The strain relief should be mounted such that it does not apply additional stress on the power connector, i.e. the cable should not be taut and should not pull the power connector at an angle.

Step 3 — Connect the Antennas

Warning: *This router is not intended for use close to the human body. Antennas should be at least 8 inches (20 cm) away from the operator.*

The MP70 has three SMA female antenna connectors:

- Cellular Main antenna connector
- Cellular Diversity antenna connector
- GNSS antenna connector

The AirLink MP70 with Wi-Fi capability also has:

- Three reverse polarity SMA male connectors for Wi-Fi antennas.
Sierra Wireless recommends cabling out the antennas.
The MP70 supports 2.4 GHz (2400–2500 MHz) and 5GHz (4900–5900 MHz) Wi-Fi bands.

For regulatory requirements concerning antennas, see [Maximum Antenna Gain](#) on page 66.

Note: The antenna should not exceed the maximum gain specified in [RF Exposure](#) on page 65. In more complex installations (such as those requiring long lengths of cable and/or multiple connections), you must follow the maximum dBi gain guidelines specified by the radio communications regulations of the Federal Communications Commission (FCC), Industry Canada, or your country's regulatory body.

To install the antennas:

1. Connect the cellular antenna to the SMA cellular antenna connector.

Mount the cellular antenna so there is at least 20 cm between the antenna and the user or bystander.

Note: Take extra care when attaching the antennas to the SMA connectors. Finger tight (approximately 0.6–0.8 Nm 5–7 in-lb.) is sufficient and the max torque should not go beyond 1.1 Nm (10 in-lb.).

2. Connect a second antenna to the SMA Diversity antenna connector.

For 3G networks, the second antenna operates as a diversity antenna, providing a second receive path.

For 4G networks, the second antenna operates as a MIMO antenna, providing a second receive path and a second transmit path.

3. If used, connect a GNSS antenna to the SMA GNSS antenna connector.

Mount the GNSS antenna where it has a good view of the sky (at least 90°).

4. For Wi-Fi-capable routers, connect the Wi-Fi antenna(s) to the SMA Wi-Fi connectors:

- For MIMO 1×1, connect the antenna to Wi-Fi connector 1.
 - For MIMO 2×2, connect the antennas to Wi-Fi connectors 1 and 2.
-

- For MIMO 3x3, connect antennas to all 3 Wi-Fi connectors.

The default ALEOS configuration is MIMO 3x3. If you are using another MIMO configuration, reconfigure the MIMO setting in ALEOS. For information on configuring MIMO, refer to the Wi-Fi chapter of the ALEOS Software Configuration User Guide for the MP70.

Note: If the antennas are located away from the router, keep the cables as short as possible to prevent the loss of antenna gain. Route the cables so that they are protected from damage and will not be snagged or pulled on. There should be no binding or sharp corners in the cable routing. Excess cabling should be bundled and tied off. Make sure the cables are secured so their weight will not loosen the connectors from the router over time.

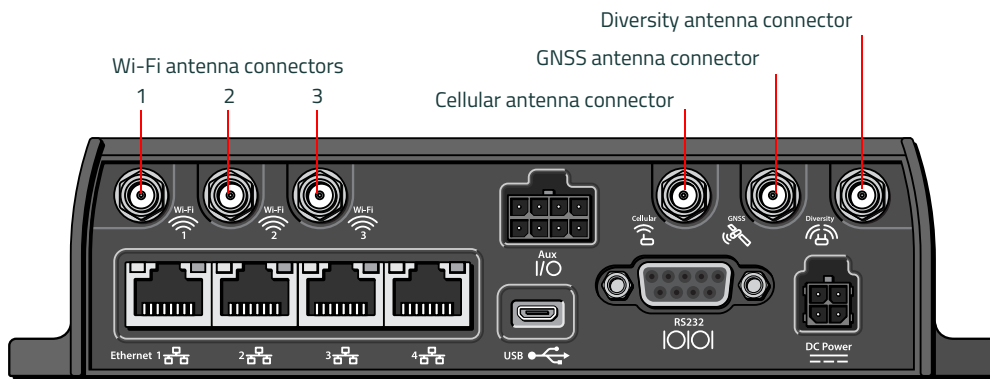

Figure 2-3: Antenna Connectors

Recommended Antenna Separation

The recommended antenna separation is related to the band frequency/wavelength. To accommodate the shortest frequency/longest wavelength band supported by the MP70, Sierra Wireless recommends a minimum antenna separation of 214 mm for best results, and if necessary, a separation of 107 mm for acceptable results.

Table 2-1: Frequency / Wavelength Range and Recommended Antenna Separation for the AirLink MP70

Service	Wavelength Range for MP70	Frequency (MHz)	Wavelength (λ) (mm)	Best Antenna Separation (mm) ($1/2 \lambda$)	Good Antenna Separation (mm) ($1/4 \lambda$)
LTE	Longest λ	700	428	214	107
LTE	Shortest λ	2600	115	58	29

Step 4 — Connect the Data Cables

The MP70 has three ports for connecting data cables:

- USB (Micro-AB)
- Ethernet (RJ-45) — Use a Cat 5e or Cat 6 Ethernet cable
- Serial Port (9-pin RS-232)

Step 5 — Connect the Power

The router's power supply cable must be connected to the vehicle's fuse box, and installed along the vehicle wall, always inside the vehicle cabin, and must not cross the vehicle's firewall protection. Always follow the vehicle manufacturer's recommendations for electrical accessories connections. All components used in the electrical connection to the vehicle should be UL Listed.

The AirLink MP70 comes with a 3 meter (10 ft.) DC power cable. You can also purchase an optional AC adapter.

Warning: *Electrical installations are potentially dangerous and should be performed by personnel thoroughly trained in safe electrical wiring procedures.*

The MP70 supports an operating voltage of 7 V–36 V, but since low voltage standby mode is enabled by default, you must supply more than 9 V at startup.

If you want to operate the router at a lower voltage, you can change the low voltage standby settings once the router is up and running. For more information, refer to the ALEOS Software Configuration User Guide (Services chapter).

Fusing

For DC installations, Sierra Wireless recommends fusing the power input using a 7.5 A, fast blow fuse, recommended to have no more than $\pm 10\%$ de-rating over the operating temperature range.

DC Voltage Transients

The AirLink MP70 has built-in protection against vehicle transients including engine cranking (down to 5.0 V) and load dump, so there is no need for external power conditioning circuits. For details, see [Industry Certification for Vehicles](#) on page 34.

Power Connector on the MP70

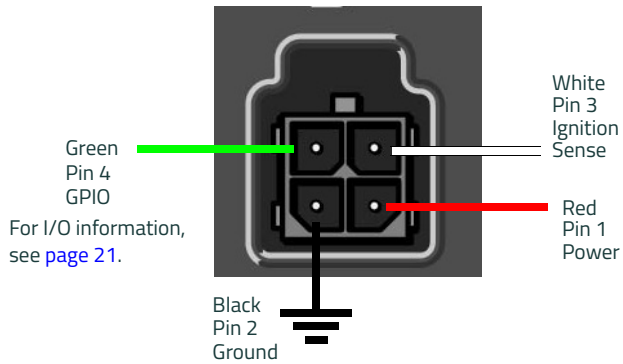

For more information, see wiring diagrams on [page 18](#).

Figure 2-4: DC Power Cable Connections (Colors indicate DC cable wire colors.)

Table 2-2: Power Connector Pin and DC Cable Wires

Pin	Name	Associated DC Cable Wire Color	Description	Type
1	Power	Red	Main power supply for device <i>Note: If you want to turn the MP70 on/off using a control line, such as a vehicle ignition line, Sierra Wireless strongly recommends that you connect the control/ignition line to Pin 3 and apply continuous power on Pin 1.</i>	PWR
2	Ground	Black	Main device ground	PWR
3	Ignition Sense	White	Ignition Sense: Connected to the vehicle ignition or an external switch. The MP70 is off when this pin is either open-circuit or grounded, and on when this pin is connected to power. <i>Note: If you do not connect pin 3 to the ignition, you MUST connect it to the positive terminal of your power supply or battery. If you are using a Sierra Wireless AC adapter, the connection is inside the cable.</i>	I
4	GPIO	Green	User configurable digital input/output or analog voltage sensing input. Connect to switch, relay or external device. For more information, see I/O Configuration on page 21 and refer to the ALEOS Software Configuration User Guide.	I/O

Connect the Router to the Vehicle's Electrical System

To connect the router to the vehicle's electrical system:

1. Ensure that the vehicle is turned off.
2. Remove the key from the ignition.
3. Disconnect the vehicle's battery:

- a. Disconnect the negative terminal **first**.
- b. Disconnect the positive terminal.
4. Connect the black (ground) wire on the DC power cable to the vehicle chassis.
5. Ensure that the MP70 is grounded. (See [Step 2 — Mount and Ground the MP70 Chassis](#) on page 12.)
6. Use a 7.5 A, fast blow fuse, recommended to have no more than $\pm 10\%$ de-rating over the operating temperature range, to connect the red (power) wire on the DC power cable to the vehicle's fuse box. (See [Figure 2-5](#).)
7. Connect the white wire (Ignition) on the DC power cable to the ignition signal from the vehicle.
8. Connect the DC power cable to the MP70.
9. Reconnect the vehicle's battery:
 - a. Connect the positive terminal **first**.
 - b. Connect the negative terminal.

Wiring Diagrams

Vehicle Installation: Option 1

This vehicle installation allows the router to operate with the vehicle, in that when the vehicle ignition is off, the router is off. For vehicle installations, Sierra Wireless recommends connecting the white Ignition Sense wire to the vehicle's ignition switch, as shown in the following illustration.

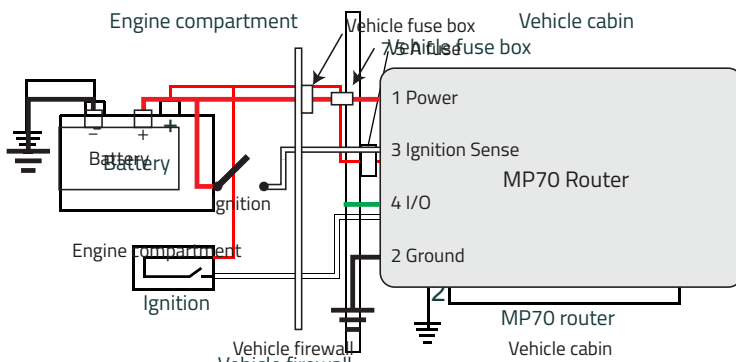

Figure 2-5: Vehicle Installation Option 1

If desired, you can configure a delay between the time the vehicle's ignition shuts off, and the time the router shuts down. A delayed shutdown is especially useful if you want to maintain a network connection while the vehicle's engine is shut off for short periods, such as in a delivery vehicle.

- Pin 1 (Power) — Use the red wire in the DC cable to connect Pin 1 to the power source. Include a 7.5 A, fast blow fuse, recommended to have no more than $\pm 10\%$ de-rating over the operating temperature range, in the input power line. Sierra Wireless recommends using a continuous (unswitched) DC power source. Connect the power through the vehicle's fuse box.
- Pin 2 (Ground) — Use the black wire in the DC cable to connect Pin 2 to ground. See also [Step 2 — Mount and Ground the MP70 Chassis](#) on page 12.
- Pin 3 (Ignition Sense) — Sierra Wireless recommends always using the Ignition Sense wire (Pin 3) to turn the router off. It should not be turned off by disconnecting the power.

Vehicle Installation: Option 2

The main difference between this installation and vehicle installation option 1 is that you can configure a timer to turn the router on at set intervals for a configured length of time; for example, 20 minutes once every 24 hours when the ignition is off. Also, instead of the router turning on and off, the router alternates between on and standby mode.

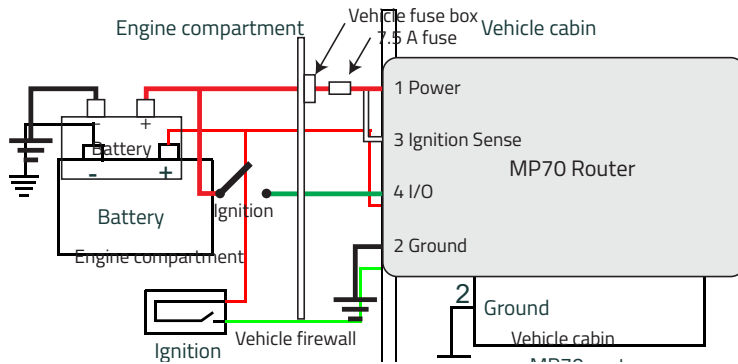

Figure 2-6: Alternate Vehicle Installation

- Pin 1 (Power) — Use the red wire in the DC cable to connect Pin 1 to the power source. Include a 7.5 A, fast blow fuse, recommended to have no more than $\pm 10\%$ de-rating over the operating temperature range, in the input power line. Sierra Wireless recommends using a continuous (unswitched) DC power source.
- Pin 2 (Ground) — Use the black wire in the DC cable to connect Pin 2 to ground. See also [Step 2 — Mount and Ground the MP70 Chassis](#) on page 12.
- Pin 3 (Ignition Sense) — Connected to power
- Pin 4 (I/O) — Connected to ignition

Fixed Installation

For fixed installations, connect the wires as shown in the figure below. You can configure Low voltage disconnect to force the router into Standby mode when the voltage is low.

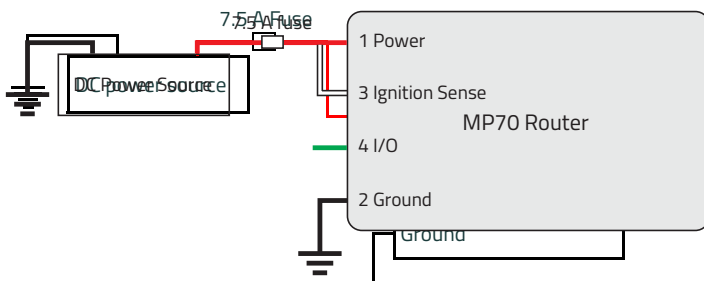

Figure 2-7: Fixed Installation without I/O

- Pin 1 (Power) — Use the red wire in the DC cable to connect Pin 1 to the power source. Include a 7.5 A, fast blow fuse, recommended to have no more than $\pm 10\%$ de-rating over the operating temperature range, in the input power line. Sierra Wireless recommends using a continuous (unswitched) DC power source.
- Pin 2 (Ground) — Use the black wire in the DC cable to connect Pin 2 to ground. See also [Step 2 — Mount and Ground the MP70 Chassis](#) on page 12.
- Pin 3 (Ignition Sense) — Connected to power

Fixed Installation with I/O Input Triggered by Standby Mode

If you have a fixed installation where you want to use the I/O to monitor an external device such as a motion detector, remote solar panel, or a remote camera, refer to [Figure 2-8](#). You can configure the I/O line to wake the router up for a configured length of time, and use low voltage disconnect to put the router in Standby mode if the voltage falls below a configured value.

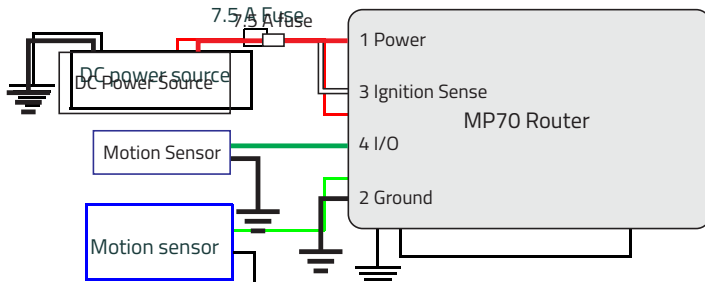

Figure 2-8: Fixed Installation with I/O

- Pin 1 (Power) — Use the red wire in the DC cable to connect Pin 1 to the power source. Include a 7.5 A, fast blow fuse, recommended to have no more than $\pm 10\%$ de-rating over the operating temperature range, in the input power line. Sierra Wireless recommends using a continuous (unswitched) DC power source.
- Pin 2 (Ground) — Use the black wire in the DC cable to connect Pin 2 to ground. See also [Step 2 — Mount and Ground the MP70 Chassis](#) on page 12.
- Pin 3 (Ignition Sense) — Connected to power
- Pin 4 (GPIO) — Use the green wire for I/O configurations. See [I/O Configuration](#) on page 21.

Step 6 (Optional) — Connect the Vehicle Bus Cable

The MP70 collects vehicle data through an OBD-II or J1939 connection from a vehicle's diagnostic port to the MP70 Aux I/O port. Accessory cables for either connection type are available separately from Sierra Wireless. See [Vehicle Bus Cables](#) on page 72.

After Vehicle Data Collection is enabled in ACEmanager, the router sends data to AirLink Mobility Manager (AMM 2.16 or later).

Note: Reporting of vehicle telemetry data from the direct vehicle connection to AirLink Management Service (ALMS) or 3rd party applications is supported in AVTA (AirLink Vehicle Telemetry Application version 1.1 or later). AVTA is an AAF application that is used to send telemetry data to a 3rd party server.

Note: An MP70 Series running ALEOS 4.9.0 or later does not require a separate scanner for reporting of vehicle telemetry data (a Sierra Wireless AirLink Vehicle Telemetry kit, which includes an OBD-II scanner, is not required). Do not connect an additional scanner or other device to the vehicle bus during normal operation. When doing vehicle maintenance that requires connecting a diagnostic tool, it is recommended to disable Direct Vehicle Bus (CAN) Data Collection on the MP70 Series.

To connect the MP70 Series with a vehicle bus cable:

- Verify that the MP70 is running ALEOS Software Version 4.9.0 or later.
- Ensure that both the MP70 and the vehicle are powered off.

3. Locate the OBD-II or J1939 port in the vehicle. The OBD-II port is an electrical socket most commonly located under the vehicle dashboard on the driver's side near the center console.
4. Attach the OBD-II or J1939 connector on the cable to the port in the vehicle.
5. Route the cable through the vehicle to where the MP70 is mounted.
6. Connect the 8-pin connector on the vehicle bus cable to the Auxiliary I/O port on the MP70.
7. Power on the router. Check that the Power, Signal, Network, and GNSS LEDs are lit as desired for your application (see [LED Behavior](#) on page 29).
8. Refer to the ALEOS 4.9.0 (or later) Software Configuration User Guide for AirLink MP70. This guide describes how to configure the MP70 to enable accurate reporting of vehicle telemetry, vehicle behavior, and dead reckoning.

Dead Reckoning Calibration

The MP70's inertial sensors must be calibrated before dead reckoning can function. Calibration begins automatically after the MP70 is turned on for the first time in a vehicle, or after the router is:

- powered off completely and powered on again
- shut down to OFF mode (Ignition Off) and turned on again
- rebooted
- disconnected and reinstalled in a different orientation.

Note: If the router has been moved from its previous installation location or orientation, you should clear the dead reckoning calibration data. In ACEmanager, go to Location > Global Settings > Advanced, and click Clear GNSS Calibration.

For optimal calibration, the vehicle should:

- be driven in open-sky conditions, with a good GPS signal
- undergo several turns
- be stopped and started several times in a straight line—braking for and accelerating away from stop signs, for example.

The calibration process can take anywhere from 5 to 20 minutes once the vehicle is in motion, depending on driving conditions.

I/O Configuration

The AirLink MP70 has five pins you can use for I/O configuration:

- Pin 4 on the power connector
- Pins 2, 3, 6, and 7 on the auxiliary I/O connector

I/O Pins

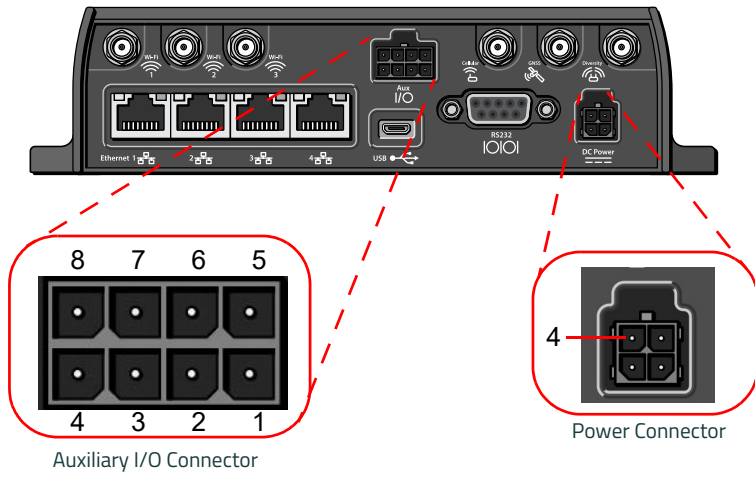

8: GND	7: DIG _{IN} / A _{IN}	6: DIG _{IN} / A _{IN}	5: CAN-L ^a
4: CAN-H ^a	3: DIG _{IN}	2: DIG _{IN}	1: GND

- a. Reserved for vehicle bus cable. See [page 72](#). Do not use with the Aux I/O cable

Figure 2-9: I/O Pin-out for Auxiliary I/O Connector and Power Connector

Table 2-3: I/O Pin-out Configuration

Location	Pin — Wire Color	Digital In	Analog In	Digital Out	Pull-up	GND	DO NOT Use	ACEmanager Configuration
Power Connector / DC Power Cable (included)	4 — Green	▶	▶	▶	▶			Digital 1 Analog 1
Auxiliary I/O Connector /I/O Cable (SKU # 6001004)	6 — Yellow	▶	▶		▶			Digital 3 Analog 3
	7 — Gray	▶	▶		▶			Digital 2 Analog 2
	2 — Orange	▶			▶			Digital 5
	3 — Purple	▶			▶			Digital 4
	1 — Black					▶		
	8 — Black					▶		
	4 — NC						▶	
	5 — NC						▶	

You can use the I/O pins as:

- Pulse counters
(See [Table 2-4](#) on page 24 and [Figure 2-10](#) on page 24.)
- digital inputs
(See [Table 2-4](#) on page 24 and [Figure 2-11](#) on page 25.)
- High side pull-ups/dry contact switch inputs
(See [Table 2-6](#) on page 26 and [Figure 2-12](#) on page 25.)
- Analog inputs
(See [Table 2-7](#) on page 26 and [Figure 2-13](#) on page 26.)
- Low side current sinks
(See [Table 2-8](#) on page 27 and [Figure 2-15](#) on page 27.)
- Digital outputs/open drains
(See [Table 2-9](#) on page 28 and [Figure 2-16](#) on page 28.)

For more information, refer to the ALEOS Software Configuration User Guide.

Note: The I/O pins can be configured in ACEmanager or ALMS to trigger standby mode, to sink current, or to pull up the voltage. If you are using the I/O line to trigger standby mode, you cannot configure it to sink current or pull up the voltage. Likewise, if you are using the I/O line to either sink current or pull up the voltage, you cannot use it to trigger standby mode.

Note: During bootup, the I/O settings remain in their default state: the internal pull-up resistor is disabled, and output current sink switch is open. After bootup, any custom I/O settings are applied. This may take approximately 30 seconds after the gateway is restarted or powered on.

You can use the I/O pins in conjunction with events reporting to configure the MP70 to send a report when the state of the monitored router changes, for example when a switch is opened or closed. For more information, refer to the ALEOS Software Configuration User Guide (Events Reporting chapter).

Pulse Counter

Pulse counter functionality is available on Pin 4 on the power connector and on Pins 2, 3, 6, and 7 on the auxiliary I/O connector.

You can connect any of these pins to a pulse counter. The digital pulse counter is not available in Standby mode.

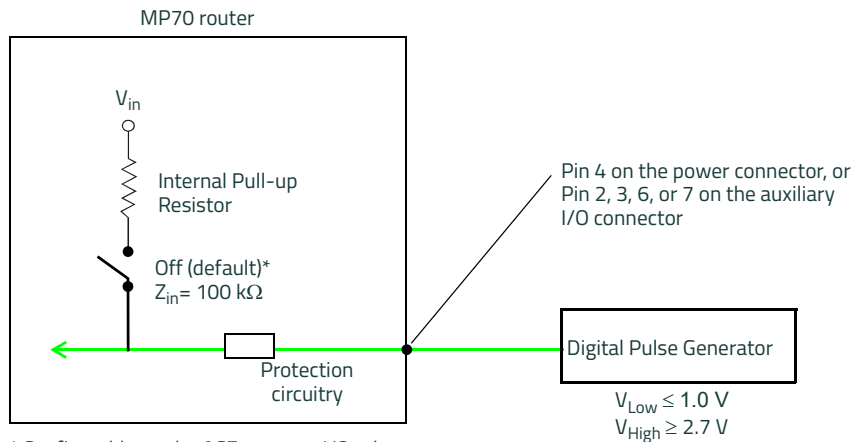

* Configurable on the ACEmanager I/O tab

Figure 2-10: Digital Input / Pulse Counter

Table 2-4: Pulse Counter

Pull-up	State	Minimum	Typical	Maximum	Units
Off	Low	—	—	1.0	V
	High	2.7	—	V_{in}	V

Digital Input

Digital input is available on Pin 4 on the power connector and on Pins 2, 3, 6, and 7 on the auxiliary I/O connector.

You can connect any of these pins to a digital input to detect the state of a switch such as a vehicle ignition, or to monitor an external device such as a motion detector, a remote solar panel, or a remote camera. Digital input can also be used with the standby timer.

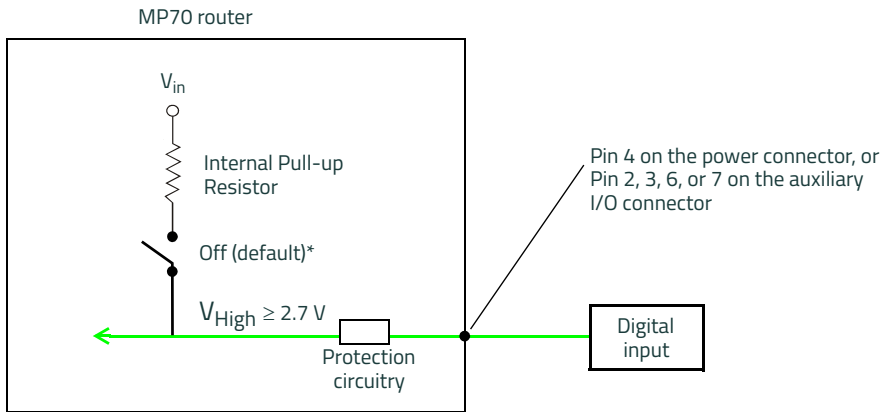

* Configurable on the ACEmanager I/O tab

Figure 2-11: Digital Input

Table 2-5: Digital Input

Pull-up	State	Minimum	Typical	Maximum	Units
Off	Low	—	—	1.0	V
	High	2.7	—	V_{in}	V

High Side Pull-up / Dry Contact Switch Input

High side pull-up / dry contact switch input is available on Pin 4 on the power connector and on Pins 2, 3, 6, and 7 on the auxiliary I/O connector.

You can connect any of these pins to a dry contact switch. The dry contact switch is not available in Standby mode.

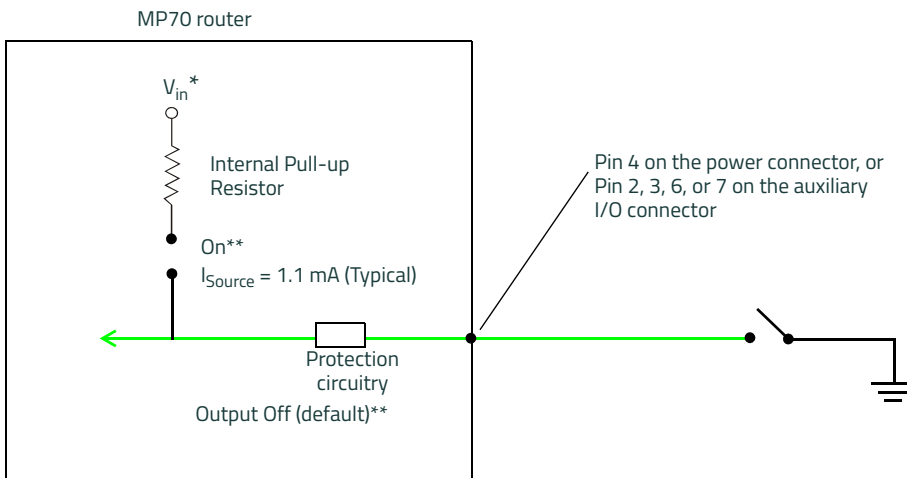

* Depending on the load, this value can range from V_{in} to $V_{in} - 2.5 V$.

** Configurable on the ACEmanager I/O tab

Figure 2-12: High Side Pull-up / Dry Contact Switch Input

Table 2-6: High Side Pull-up / Dry Contact Switch Input

	Minimum	Typical	Maximum	Units	Comments
Source Current	0.6 $V_{in} = 7\text{ V}$	1.1 $V_{in} = 12\text{ V}$	3.5 $V_{in} = 36\text{ V}$	mA	Maximum current the voltage output can provide (depends on V_{in})
V_{out}	$V_{in} - 2.5$	—	V_{in}	V	The voltage on Pin 4 when the high side pull-up is enabled (depends on V_{in} and power consumption)

Analog Input

You can connect Pin 4 on the power connector or Pins 6 or 7 on the auxiliary I/O connector to an analog sensor. As an analog input (voltage sensing pin), the router monitors voltage changes in small increments. This allows you to monitor equipment that reports status as an analog voltage.

The pin detects inputs of 0.5 – 36 V referenced to ground. When used with a sensor to transform values into voltages, the pin can monitor measurements such as temperatures, sensors, or input voltage.

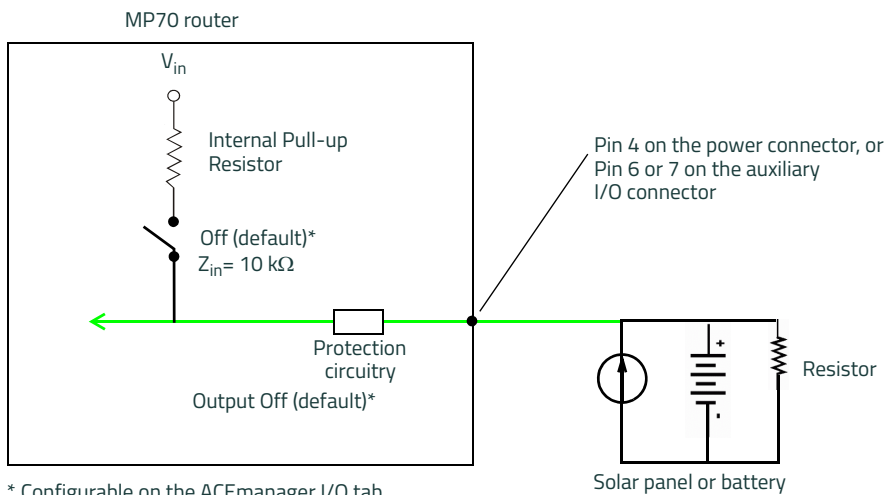

* Configurable on the ACEmanager I/O tab

Figure 2-13: Analog Input

Table 2-7: Analog Input

Pull-up		Minimum	Typical	Maximum	Units	Comments
Off	Analog Input Range	0.5	—	36	V	—
	Analog Input Accuracy	-1.5%	0.50%	1.5%	—	—

Data sampling is handled by a dedicated microprocessor. In order to filter noisy signals, twenty measurements are taken over a 250 ms interval and they are averaged to generate a sample. If the change since the last sample is significant, a notification is sent to the CPU for updating the current value displayed in the user interface and for use by Events Reporting.

Changes are considered significant if the change is 150 mV or more. If there has not been a significant change to the parameter being monitored, the CPU reads a sample every 2.5 minutes, which detects small changes.

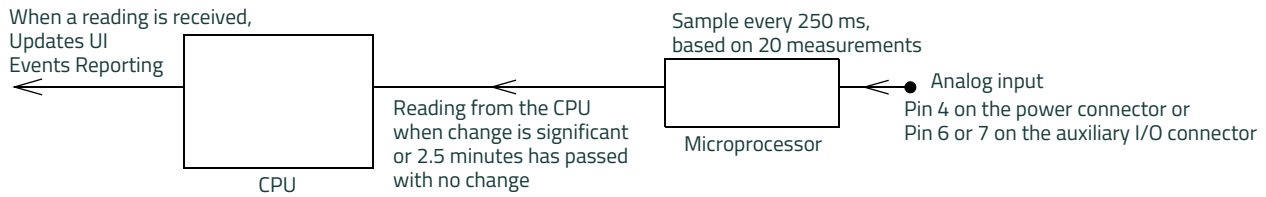
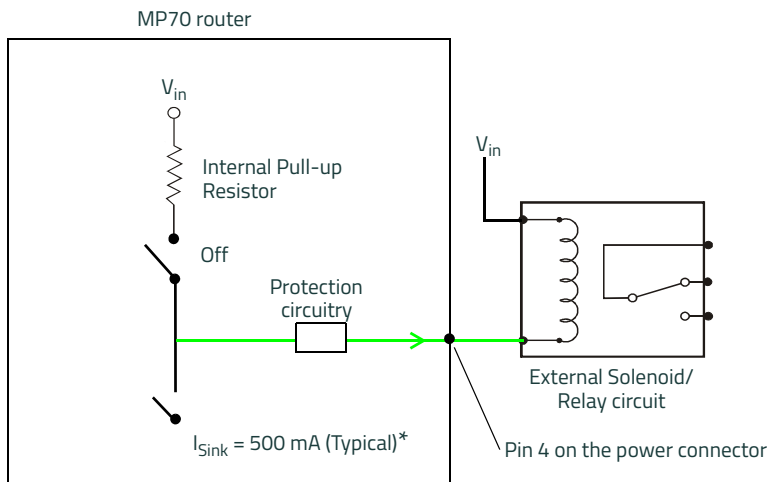

Figure 2-14: Analog Input Sampling and Reading

Note: The same method is used to sample the input voltage and the internal board temperature for Events Reporting. The significant changes are 300 mV for the input voltage and 1 °C for the board temperature.

Low Side Current Sink Output

Low side current sink output, for example to drive a relay, is only available using Pin 4 on the power connector.



* See Table 2-8 on page 27 for more details.

Figure 2-15: Low Side Current Sink

Table 2-8: Low Side Current Sink

Pull-up	State	Minimum	Typical	Maximum	Units	Comments
Off	On	250	500	1000	mA	I_Typical = 25 °C I_Min = 70 °C I_Max = -40 °C
Off	Off	—	0	—	mA	Vin = 12

Note: The router protection circuitry has a high-impedance (~125 k?) path to ground. If Pin 4 is connected to 12 V, there will be a small current flow (~100 ?A) into Pin 4 during bootup. This flow is countered when the internal pull-up resistor (10 k?) becomes active after bootup. Depending on your application, you may need to install an external pull-up resistor (10 k?) in order to nullify the small input current flow for the first 30 seconds during bootup.

Digital Output/Open Drain

Digital output/open drain, for example to drive an external digital input, is only available using Pin 4 on the power connector.

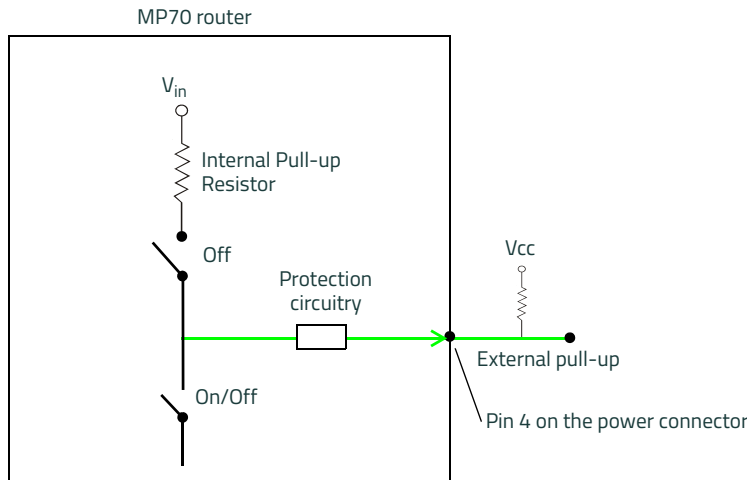

Figure 2-16: Digital Output / Open Drain

Table 2-9: Digital Output / Open Drain

Pull-up	State	Minimum	Typical	Maximum	Units	Comments
Off	Off	Open Circuit	—	—	—	—
	Active Low	—	—	0.5	V	5 mA, ≤ 5 V

Step 7 — Check the Router Operation

- When power is supplied to the AirLink MP70 router, it powers up automatically, as indicated by the flashing LEDs. If it does not turn on, ensure that the:
 - Power connector is plugged in and supplying voltage greater than 9 V.

Note: Although the MP70 operates in the range 7 V–36 V, low voltage standby mode is enabled by default. In order to avoid the router powering on in standby mode, ensure that it is supplied with more than 9 V at startup. (You can change the low voltage standby mode settings once the router is operational. If the Power LED is red, the router is in standby mode.)

- Ignition Sense (pin 3) is connected to the battery or power source (see [Step 5 — Connect the Power](#) on page 16 for details)

LED Behavior

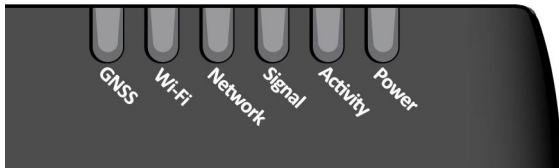

Table 2-10: LED Behavior

LED	Color / Pattern	Description
Power	Off	No power or input voltage ≥ 36 VDC or ≤ 7 VDC
	Solid Green	Power is present.
	Solid Red	Standby mode If you want to operate the router using less than 9 V, change the Low Voltage Standby settings (Refer to the ALEOS Software Configuration User Guide, Services chapter)
	Flashing Green	When you press the reset button for less than 5 seconds, flashing green indicates when to release the reset button to reboot the router.
	Flashing Red	When you press the reset button for 5–20 seconds, flashing red indicates when to release the reset button to reset the router to the factory default settings.
	Flashing Amber	When you press the reset button for more than 20 seconds, flashing amber indicates when to release the reset button to enter Recovery mode. (See Recovery Mode on page 32.)
Signal	Solid Green	Good signal (equivalent to 3–5 bars)
	Solid Amber	Fair signal (equivalent to 2 bars)
	Flashing Amber	Poor signal (equivalent to 1 bar) Sierra Wireless recommends moving the router, if possible, to a location with a better signal.
	Flashing Red	Inadequate (equivalent to 0 bars) Sierra Wireless recommends moving the router to a location with a better signal.
<i>Note: The quality of the signal strength is measured using the appropriate parameters for the radio technology in use.</i>		
Network	Solid Green	Connected to an LTE network
	Solid Amber	Connected to a 3G or 2G network
	Flashing Green	Connecting to the network
	Flashing Red	No network available
	Flashing Red / Amber	Network Operator Switching is enabled, but the router is unable to locate the required firmware. For more information, refer to the ALEOS Software Configuration User Guide (Admin chapter).

Table 2-10: LED Behavior

LED	Color / Pattern	Description
Activity	Flashing Green	Traffic is being transmitted or received over the WAN interface.
	Flashing Red	Traffic is being transmitted or received over the serial port. This behavior only appears if the MP70 is configured to display it. For more information, refer to the ALEOS Software Configuration Guide (Serial chapter).
	Flashing Amber	Traffic is being transmitted or received over both the WAN interface and the serial port. This behavior only appears if the MP70 is configured to display it. Refer to the ALEOS Software Configuration Guide (Serial chapter).
GNSS	Green	The router has a GNSS fix.
	Flashing	No GNSS fix
	Off	GNSS is disabled. (Configurable in ACEmanager and ALMS)
Wi-Fi ^a	Off	Wi-Fi is disabled. (Configurable in ACEmanager and ALMS)
	Solid Green	Wi-Fi is enabled.
	Solid Amber	Wi-Fi is enabled, and the router is connected to an Access Point. (i.e. Wi-Fi is being used as the WAN connection)
	Flashing (Green or Amber)	Wi-Fi traffic is being sent or received.
ALL	Green LED chase	Radio module reconfiguration / firmware update or Network Operator Switching is in progress.
	Amber LED chase	ALEOS software update is in progress.
	Red LED chase	The router is in Recovery mode.
	Solid Amber	ALEOS software update complete (all LEDs except the Power LED)

a. MP70 Wi-Fi only

Ethernet LEDs

The connector has two LEDs that indicate speed and activity. When looking into the connector:

- Activity—The right LED indicates the link status:
 - Solid—Link
 - Blinking Amber—Activity
 - Off—No link
- Connection Speed—The left LED indicates the Ethernet connection speed:
 - Solid Orange—1000 Mbps (Gigabit)
 - Off—10/100 Mbps

Step 8—Configure the Software

You can configure the ALEOS software on the MP70 using:

- [ACEmanager](#) (browser-based application)
- [AirLink Management Service](#) (cloud-based application)
- [AirLink Mobility Manager](#) (unified software platform deployed in the enterprise data center)
- [AT Commands](#)

Configuring with ACEmanager

To access ACEmanager:

1. Connect a laptop to the router with an Ethernet cable.
2. Launch your web browser and go to:
 - **https://192.168.13.31:9443** (ALEOS 4.14.0 and later)
 - **http://192.168.13.31:9191** (ALEOS 4.13.0 or previous)

Note: It takes the router about 1 minute to respond after power up.

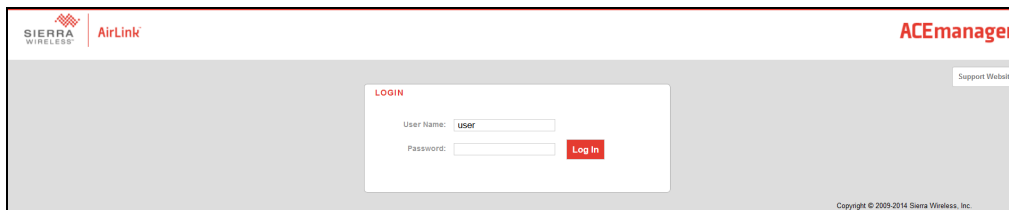

Figure 2-17: ACEmanager login window

3. Enter the default password (printed on the label on the base of the unit) and click Log In.

Note: For system security, ensure that you change the default password as soon as possible.

4. Refer to the ALEOS Software Configuration User Guide for information on how to use ACEmanager to configure your MP70.

Configuring with AirLink Management Service

AirLink Management Service (ALMS) allows remote management of all your routers from one user interface.

Some of its features include:

- Centralized, remote monitoring for all your AirLink routers
- Continuous status monitoring of important health data such as signal strength
- Location monitoring, including world map views
- Complete ALEOS reporting and configuration, including historical views of ALEOS information
- Configure individual routers or use templates to perform batch configurations of your AirLink routers
- Single click over-the-air firmware updates to all your routers
- Compatible with all carriers or mobile network operators

To get started, either call your Sierra Wireless Partner or visit:

www.sierrawireless.com/ALMS

Configuring with AMM

AirLink Mobility Manager (AMM) is a Network Management solution that provides a consolidated view of the entire vehicle fleet and enables simplified management, control and monitoring of connected AirLink routers. AMM is a licensed, unified software platform deployed in the enterprise data center. It enables:

- Mobile network and asset management
- Over-the-air registration, configuration and software updates
- Consolidated network view of an entire fleet, in-field applications and mobile assets, using a virtual dashboard to monitor, report, manage, and troubleshoot all mobile resources as required.

If you require a network management solution deployed in your data center, contact your Sierra Wireless sales representative for a demonstration of the AMM capabilities.

Configuring with AT Commands

For a complete list of AT commands, refer to the ALEOS Software Configuration User Guide.

Reboot the MP70

To reboot the MP70, either:

- On the router, press the Reset button for less than 5 seconds. (Release the button when the Power LED flashes green.)
- In ACEmanager, click the Reboot button on the toolbar.

Reset the MP70 to Factory Default Settings

To reset the router to the factory default settings, either:

- On the router, press the Reset button for between 5 and 20 seconds. (Release the button when the Power LED flashes red.)
Once the LEDs resume their normal operating behavior, the reset is complete.
–Or–
- In ACEmanager, go to Admin > Advanced and click the Reset to Factory Default button.

Note: When you reset the router to the factory default settings, some settings such as the network ID, network password, custom APNs, Primary SIM, low voltage standby are preserved by default. However, you can configure the MP70 to reset all values. For more details, refer to the ALEOS Software Configuration User Guide (Admin chapter).

Recovery Mode

If the router fails to boot properly, it automatically enters recovery mode, or, if the router is unresponsive to ACEmanager input and AT commands, you can manually put the router into recovery mode.

Recovery mode enables you to update the ALEOS software and return the router to working order. (For details, refer to the ALEOS Software Configuration User Guide — Configuring your router chapter.)

To enter Recovery mode manually:

- On the router, press the Reset button for more than 20 seconds. (Release the button when the Power LED flashes amber.)

To recover the router:

- Update ALEOS using the Recovery mode interface. Once the new ALEOS version is successfully uploaded and installed, the router reboots and exits recovery mode. When the process is complete, the ACEmanager login screen appears.

Note: After the recovery, you need to reload the radio module firmware store and templates.

To exit Recovery mode, if it has been inadvertently entered, do one of the following:

- Press the reset button on the router to reboot it.
- Click the Reboot button on the Recovery screen.
- Wait 10 minutes. If no action is taken within 10 minutes of the device entering Recovery mode (for example, if the Recovery screen has not been loaded by the web browser), it automatically reboots and exits Recovery mode.

For more information, refer to the ALEOS Software Configuration User Guide (Gateway Configuration chapter).

3: Specifications

This chapter describes the MP70 Series router specifications.

Certification and Interoperability

Emissions / Immunity	MP70, MP70 LTE-A Pro: <ul style="list-style-type: none"> ▪ FCC ▪ Industry Canada ▪ CE (Including EMC Test case for vehicle installation EN301489) ▪ ACMA RCM MP70E: <ul style="list-style-type: none"> ▪ FCC
Safety	<ul style="list-style-type: none"> ▪ CB Scheme ▪ UL 60950
Industry Certification for Vehicles	<ul style="list-style-type: none"> ▪ E-Mark UNECE Regulation No. 10 Rev. 5 ▪ ISO7637-2 ▪ SAE J1455 (Shock & Vibration)
Industry Certification for Rail	<ul style="list-style-type: none"> ▪ EN 50155 (Rolling Stock)
Environmental Compliance	<ul style="list-style-type: none"> ▪ RoHS 2011/65/EU (RoHS 2) ▪ WEEE ▪ REACH
GSM/HSPA+ Certifications	MP70, MP70 LTE-A Pro: <ul style="list-style-type: none"> ▪ PTCRB ▪ GCF-CC ▪ RED MP70E: <ul style="list-style-type: none"> ▪ PTCRB

Reliability

The MTBF for the MP70 (Ground Benign, 25 °C) is 285,968 hours (32.6 years)

MTBF calculations are performed per Telcordia "Reliability Prediction Procedure for Electronic Equipment" document number SR-332, Method I, Issue 3.

Environmental Testing

Test Method	Category	Description
MIL-STD-810G, Test method 514.6 IEC 60068-2-64	Vibration	Frequency range: 10 Hz–150 Hz Spectrum level: 2.24G on all axes for 8 hours/axis Operating mode: powered on
MIL-STD-810G, Test method 516.6	Mechanical Shock	Half-sine 40G, 15–23 ms, (+/-X, +/-Y, +/-Z directions, 10 times per axis) Operating mode: powered on
MIL-STD-810G, Test methods 501.5, 502.5	Temperature	Rugged category: -30 °C to 70 °C 2-hour soak each temp high/low 3 cycles ramp <= 3 °C/minute Operating mode: powered on
MIL-STD-810G, Test methods 501.5, 502.5	Temperature	Rugged category: -40 °C to 85 °C 2-hour soak each temp high/low 50 cycles ramp <= 3 °C/minute Operating mode: unpowered
MIL-STD-810G, Test method 507.5	Humidity	10 × 48-hour cycles: <ul style="list-style-type: none"> ▪ 4-hour ramp to 60 °C (95% humidity), hold 8 hours ▪ 4-hour ramp down to 30 °C (85% to 95% relative humidity), hold 21 hours ▪ 1-hour ramp down to 20 °C, hold 4 hours ▪ 1-hour ramp up to 30 °C, hold 5 hours Operating mode: powered on
IEC 60529	Water Resistance ^a	Subject to spraying water. Water sprayed at an angle up to 60° on either side of the vertical for 10 minutes. Operating mode: unpowered
IEC 61000-4-2	Electrostatic Discharge	+/-2 kV, +/-4 kV, +/-6 kV, +/-8 kV (Contact and Air) +/-15 kV (Air at antenna connector) Operating mode: powered on
IEC 60068-2-32	Free Fall Test	1 m drop height 6 drops onto concrete, 2 per axis: X, Y, Z Operating mode: unpowered
IEC 60068-2-70 Part 2, Test Xb	Marking	The markings are rubbed with water for 10 cycles, then with lubricating oil for 10 cycles. Operating mode: unpowered
ISTA 2A 2001, test categories 1, 4, 5, & 6	Package	In shipping packaging. Cargo vibration and drop test.

a. Ingress protection rating is IP64 (if RJ-45 ports are connected)

Included Radio Module Firmware

For carrier certification, please see the Tech Spec at sierrawireless.com.

MP70 LTE-A: NA and EMEA

- Generic (default)
- Verizon Wireless
- AT&T
- Sprint

MP70 LTE-A: APAC

- Generic (default)
- Telstra

MP70 LTE-A Pro: North America

- Generic (default)
- AT&T (FirstNet with Carrier Aggregation)
- Sprint
- Verizon
- Bell
- Sierra Wireless

MP70 LTE-A Pro: Global

- Generic (default)
- Telstra

Network Technology

LTE and HSPA

For a list of supported bands, see [Table 3-5](#) on page 44 and [Table 3-7](#) on page 46 and [Table 3-9](#) on page 48.

Host Interfaces

Antenna connectors	<ul style="list-style-type: none"> ▪ On all units: <ul style="list-style-type: none"> • Cellular SMA • Diversity SMA • Active GNSS SMA ▪ On units with Wi-Fi option: <ul style="list-style-type: none"> • Three RP SMA Wi-Fi
USB	<hr style="border: 2px solid red;"/> <p>Warning: <i>Do not use the USB port in a potentially explosive environment.</i></p> <hr style="border: 2px solid red;"/> <ul style="list-style-type: none"> ▪ USB 2.0 Micro-AB connector complies with USB Version 2.0 for high speed operation ▪ Can be configured to operate in one of two modes: <ul style="list-style-type: none"> • Virtual Ethernet Port: The MP70 behaves as if the PC were connected to an Ethernet port, allowing access to the Internet and the MP70's internal web server. This is the default setting. • Virtual Serial Port: The MP70 behaves as if it was connected to a standard serial port. The primary use of this interface is for the AT command line interface of ALEOS and for diagnostic access to the radio module. <p>By default, the USB port is configured as a virtual Ethernet port.</p> ▪ A Windows driver must be installed on the PC in order to support USB use. The drivers are available for download on Sierra Wireless' support web site: source.sierrawireless.com/resources/airlink/software_downloads/airlink_usb_driver/ ▪ The ALEOS Software Configuration User Guide contains the details of USB mode configuration and driver installation. ▪ Sierra Wireless recommends you: <ul style="list-style-type: none"> • Use a USB 2.0 cable • Connect directly to your computer for best throughput.

<p>Ethernet</p>	<ul style="list-style-type: none"> 10/100/1000 Base-T RJ-45 Ethernet IEEE 802.3 Ethernet specification for 1000 Mbps speed (Gigabit Ethernet) with fallback to 100 or 10 Mbps (Cat 5e or Cat 6 cable is required for Gigabit Ethernet) Auto-crossover support Auto-negotiation detects the speed of the connecting device 																																								
<p>Serial Port</p>	<ul style="list-style-type: none"> 9-pin RS-232 serial port connects directly to most computers or other devices with a standard serial straight-through cable <hr/> <p><i>Note: If you have a DCE device, you need to use a null modem (cross-over) cable.</i></p> <hr/> <ul style="list-style-type: none"> Used for connecting serial devices and configuration Complies with the EIA RS-232D specification for DCE equipment Output driver levels swing from -7 VDC to +7 VDC with normal loading <div data-bbox="451 701 727 898" data-label="Diagram"> </div> <p><i>Figure 3-1: DB-9 Female Serial Connector</i></p> <p>Table 3-1: Serial Connector Pin-out</p> <table border="1" data-bbox="402 1010 1084 1543"> <thead> <tr> <th>Name</th> <th>Pin</th> <th>Description</th> <th>Type</th> </tr> </thead> <tbody> <tr> <td>DCD</td> <td>1</td> <td>Data Carrier Detect</td> <td>OUT</td> </tr> <tr> <td>RXD</td> <td>2</td> <td>Receive Data</td> <td>OUT</td> </tr> <tr> <td>TXD</td> <td>3</td> <td>Transmit Data</td> <td>IN</td> </tr> <tr> <td>DTR</td> <td>4</td> <td>Data Terminal Ready</td> <td>IN</td> </tr> <tr> <td>GND</td> <td>5</td> <td>Main GND. Connected internally to BOARD GND</td> <td>GND</td> </tr> <tr> <td>DSR</td> <td>6</td> <td>Data Set Ready</td> <td>OUT</td> </tr> <tr> <td>RTS</td> <td>7</td> <td>Ready To Send</td> <td>IN</td> </tr> <tr> <td>CTS</td> <td>8</td> <td>Clear To Send</td> <td>OUT</td> </tr> <tr> <td>RI</td> <td>9</td> <td>Not connected</td> <td>—</td> </tr> </tbody> </table>	Name	Pin	Description	Type	DCD	1	Data Carrier Detect	OUT	RXD	2	Receive Data	OUT	TXD	3	Transmit Data	IN	DTR	4	Data Terminal Ready	IN	GND	5	Main GND. Connected internally to BOARD GND	GND	DSR	6	Data Set Ready	OUT	RTS	7	Ready To Send	IN	CTS	8	Clear To Send	OUT	RI	9	Not connected	—
Name	Pin	Description	Type																																						
DCD	1	Data Carrier Detect	OUT																																						
RXD	2	Receive Data	OUT																																						
TXD	3	Transmit Data	IN																																						
DTR	4	Data Terminal Ready	IN																																						
GND	5	Main GND. Connected internally to BOARD GND	GND																																						
DSR	6	Data Set Ready	OUT																																						
RTS	7	Ready To Send	IN																																						
CTS	8	Clear To Send	OUT																																						
RI	9	Not connected	—																																						

SIM Card Interface

- The MP70 has two 6-pin SIM sockets for mini-SIM (2FF) SIM cards, operated at 1.8 V/3.3 V.
- This interface is compliant with the applicable 3GPP standards for USIM.

Input/Output

For more information, see [page 24](#).

- Configurable I/O pin on power connector
- Auxiliary I/O connector with 4 I/O pins

Power Adapter Pins

4-Pin connector:

- Power
- Ground
- Configurable digital I/O and analog voltage input sensing
- Configurable ignition sense

Reset

Manual reset button or using ACEmanager

LEDs

See [LED Behavior](#) on page 29.

6 LEDs:

- Power
- Network
- Signal
- Activity
- GNSS
- Wi-Fi

Screw Torque Settings

- Mount screws: 1.1 N-m (10 in-lb)
- Antennas: Finger tight (5 – 7 in-lb) is sufficient. The max torque should not go beyond 1.1 N-m (10 in-lb).

Operating Voltage

By default, the router is configured to enter Standby mode at 9 V. If you want to operate the router at less than 9 volts, power it on using at least 9 V, launch ACEmanager, go to Services > Power Management and adjust the Standby mode settings.

The maximum ripple voltage to guarantee analog input accuracy must be 100 mVpp.

Power Specifications

Table 3-2: Power Supply Specifications

Pin	Name	Specification	Parameter	Minimum	Maximum
1	VCC	Voltage range	VCC	7 V	36 V

Table 3-3: Ignition Sense Specifications

Pin	Name	Input Impedance (Typ)	Specification	Parameter	Minimum	Maximum
3	IS (Input only)	110 k Ω	Input low state voltage (maximum)	V_{IL}	—	2 V
			Input high state voltage (minimum guaranteed)	V_{IH}	3 V	V_{in}

*Note: If you do not connect this pin to the ignition, you **MUST** connect it to the positive terminal of your power supply or battery. The device looks for a qualified voltage on this pin as part of the power up sequence. If it doesn't see a qualified voltage, the device will not turn on. If you are using a Sierra Wireless AC power adapter, the connection is inside the cable.*

GNSS Technology

Satellite channels	Maximum 48 tracking channels and 2 fast acquisition channels
Constellations	<ul style="list-style-type: none"> ▪ GPS ▪ Galileo ▪ GLONASS ▪ BeiDou ▪ QZSS
Protocol	NMEA 0183 V3.0
Acquisition time (Time to first fix)	<ul style="list-style-type: none"> ▪ Hot start: 1 second ▪ Cold start: 30 seconds
Sensitivity	Indoor sensitivity (tracking mode): -162 dBm
Horizontal accuracy ^a	< 1.8 m (GPS & GLONASS), < 1.5 m (GPS & BeiDou)

a. 50% probability

Protocols

- Network: TCP/IP, UDP/IP, DNS
- Routing: NAT, Host Port Routing, DHCP, PPPoE, VLAN, VRRP, Reliable Static Route
- Applications: SMS, Telnet/SSH, Reverse Telnet, SMTP, SNMP, SNTP
- Serial: TCP/UDP PAD mode, Modbus (ASCII, RTU, Variable), PPP
- GNSS: NMEA 0183 V 3.0, TAIP, RAP, Xora

Wi-Fi Performance

Technology	Frequency	MIMO	20 MHz ^a	40 MHz ^a	80 MHz ^a
802.11n	2.4 GHz	1 × 1	72 Mbps		
		2 × 2	144 Mbps		
		3 × 3	216 Mbps		
	5 GHz	1 × 1	72 Mbps	150 Mbps	
		2 × 2	144 Mbps	300 Mbps	
		3 × 3	216 Mbps	450 Mbps	
802.11ac	5 GHz	1 × 1	87 Mbps	200 Mbps	433 Mbps
		2 × 2	173 Mbps	400 Mbps	867 Mbps
		3 × 3	289 Mbps	600 Mbps	1.3 Gbps

a. Theoretical maximum performance. Actual data rates vary.

Wi-Fi Output Power

Technology	Frequency	Max Output Power
802.11n	2.4 GHz	26 dBm ±2 dB
	5 GHz	24 dBm ±2 dB
802.11ac	5 GHz	23 dBm ±2 dB

Wi-Fi Channels Supported

Note: By default, ALEOS enables all supported Wi-Fi channels. You can set the number of enabled Wi-Fi channels in ACEmanager or ALMS using the Wi-Fi Country Code setting. The default Country Code is United States. All other Country Code settings configure a subset of channels; they do not enable channels beyond those available in the default setting.

	Channel	Frequency (GHz)	20 MHz	40 MHz	80 MHz
2.4 GHz	1	2.412	✓		
	2	2.417	✓		
	3	2.422	✓		
	4	2.427	✓		
	5	2.432	✓		
	6	2.437	✓		
	7	2.442	✓		
	8	2.447	✓		
	9	2.452	✓		
	10	2.457	✓		
	11	2.462	✓		
5 GHz	36	5.180	✓	✓	✓
	40	5.200	✓	✓	✓
	44	5.220	✓	✓	✓
	48	5.240	✓	✓	✓
	149	5.745	✓	✓	✓
	153	5.765	✓	✓	✓
	157	5.785	✓	✓	✓
	161	5.805	✓	✓	✓
	165	5.825	✓		

Radio Frequency Bands

The radio frequency bands supported by the MP70 vary by SKU configuration. The cellular radio module type is printed on the label on the bottom of the router and can be viewed in ACEmanager (Status > About).

Table 3-4: SKU Configurations

SKU	Cellular Radios	Model	Region
1103438	MC7354	MP70E	US
1103439		MP70E Wi-Fi	US
1102709	MC7455/30	MP70	North America & EMEA
1102713		MP70	APAC
1102743		MP70 Wi-Fi	North America & EMEA
1102745		MP70 Wi-Fi	APAC
1104071	EM7511/65	MP70 LTE-A Pro	North America
1104072		MP70 LTE-A Pro	Global
1104073		MP70 LTE-A Pro Wi-Fi	North America
1104074		MP70 LTE-A Pro Wi-Fi	Global

Table 3-5: MP70 Radio Module MC7455 North America and EMEA

Radio Technology	SKU				Band	Frequencies
	Generic	Verizon Wireless	AT&T	Sprint		
LTE	✓		✓	✓	Band 1	Tx: 1920–1980 MHz Rx: 2110–2170 MHz
	✓	✓	✓	✓	Band 2	Tx: 1850–1910 MHz Rx: 1930–1990 MHz
	✓		✓	✓	Band 3	Tx: 1710–1785 MHz Rx: 1805–1880 MHz
	✓	✓	✓	✓	Band 4	Tx: 1710–1755 MHz Rx: 2110–2155 MHz
	✓	✓	✓	✓	Band 5	Tx: 824–849 MHz Rx: 869–894 MHz
	✓		✓	✓	Band 7	Tx: 2500–2570 MHz Rx: 2620–2690 MHz
	✓		✓	✓	Band 8	Tx: 880–915 MHz Rx: 925–960 MHz
	✓		✓	✓	Band 12	Tx: 699–716 MHz Rx: 729–746 MHz
	✓	✓	✓	✓	Band 13	Tx: 777–787 MHz Rx: 746–756 MHz
	✓		✓	✓	Band 20	Tx: 832–862 MHz Rx: 791–821 MHz
	✓		✓	✓	Band 25	Tx: 1850–1915 MHz Rx: 1930–1995 MHz
	✓		✓	✓	Band 26	Tx: 814–849 MHz Rx: 859–894 MHz
	✓		✓	✓	Band 29	Tx: n/a Rx: 717–728 MHz
	✓		✓	✓	Band 41	2496–2690 MHz (TDD)

Table 3-5: MP70 Radio Module MC7455 North America and EMEA (Continued)

Radio Technology	SKU				Band	Frequencies
	Generic	Verizon Wireless	AT&T	Sprint		
HSPA+	✓	✓	✓	✓	Band 1	Tx: 1920 – 1980 MHz Rx: 2110 – 2170 MHz
	✓	✓	✓	✓	Band 2	Tx: 1850 – 1910 MHz Rx: 1930 – 1990 MHz
	✓	✓	✓	✓	Band 3	Tx: 1710 – 1785 MHz Rx: 1805 – 1880 MHz
	✓	✓	✓	✓	Band 4	Tx: 1710 – 1755 MHz Rx: 2110 – 2155 MHz
	✓	✓	✓	✓	Band 5	Tx: 824 – 849 MHz Rx: 869 – 894 MHz
	✓	✓	✓	✓	Band 8	Tx: 880 – 915 MHz Rx: 925 – 960 MHz

Table 3-6: Radio Module MC7455 Conducted Transmit Power

Band	Conducted Tx Power (dBm)	Notes
LTE		
Bands 1, 2, 3, 4, 5, 8, 12, 13, 20, 25, 26	+23±1	
Bands 7, 30, 41	+22±1	
HSPA+		
Band 1 (IMT 2100 12.2 kbps) Band 2 (UMTS 1900 12.2 kbps) Band 4 (AWS 1700/2100 12.2 kbps) Band 5 (UMTS 850 12.2 kbps) Band 8 (UMTS 900 12.2 kbps)	+23±1	Connectorized (Class 3)

Table 3-7: MP70 Radio Module MC7430 Asia Pacific

Radio Technology	SKU			Band	Frequencies
	Generic	Telstra	DoCoMo		
LTE	✓	✓	✓	Band 1	Tx: 1920–1980 MHz Rx: 2110–2170 MHz
	✓	✓	✓	Band 3	Tx: 1710–1785 MHz Rx: 1805–1880 MHz
	✓	✓	✓	Band 5	Tx: 824–849 MHz Rx: 869–894 MHz
	✓	✓	✓	Band 7	Tx: 2500–2570 MHz Rx: 2620–2690 MHz
	✓	✓	✓	Band 8	Tx: 800–915 MHz Rx: 925–960 MHz
	✓	✓	✓	Band 18	Tx: 815–830 MHz Rx: 860–875 MHz
	✓	✓	✓	Band 19	Tx: 830–845 MHz Rx: 875–890 MHz
	✓	✓	✓	Band 21	Tx: 1447.9–1462.9 MHz Rx: 1495.9–1510.9 MHz
	✓	✓		Band 28	Tx: 703–748 MHz Rx: 758–803 MHz
	✓	✓	✓	Band 38	2570–2620 MHz (TDD)
	✓	✓	✓	Band 39	1880–1920 MHz (TDD)
	✓	✓	✓	Band 40	2300–2400 MHz (TDD)
	✓	✓	✓	Band 41	2496–2690 MHz (TDD)

Table 3-7: MP70 Radio Module MC7430 Asia Pacific (Continued)

Radio Technology	SKU			Band	Frequencies
	Generic	Telstra	DoCoMo		
HSPA+	✓	✓	✓	Band 1	Tx: 1920–1980 MHz Rx: 2110–2170 MHz
	✓	✓	✓	Band 5	Tx: 824–849 MHz Rx: 869–894 MHz
	✓	✓	✓	Band 6	Tx: 830–840 MHz Rx: 875–885 MHz
	✓	✓	✓	Band 8	Tx: 880–915 MHz Rx: 925–960 MHz
	✓	✓		Band 9	Tx: 1749.9–1784.9 MHz Rx: 1844.9–1879.9 MHz
	✓	✓	✓	Band 19	Tx: 830–845 MHz Rx: 875–890 MHz
TD-SCDMA				Band 39	1880–1920 MHz

Table 3-8: Radio Module MC7430 Conducted Transmit Power

Band	Conducted Tx Power (dBm)	Notes
LTE		
Bands 1, 3, 5, 8, 18, 19, 21, 28, 39	+23±1	
Band 7, 38, 40, 41	+22±1	
HSPA+		
Band 1 (IMT 2100 12.2 kbps) Band 5 (UMTS 850 12.2 kbps) Band 6 (UMTS 800 12.2 kbps) Band 8 (UMTS 900 12.2 kbps) Band 9 (UMTS 1700 12.2 kbps) Band 19 (UMTS 850 12.2 kbps)	+23±1	Connectorized (Class 3)
TD-SCDMA		
Band 39	+23±1	

Table 3-9: MP70E Radio Module MC7354 US

Radio Technology	SKU				Band	Frequencies
	Generic	Verizon Wireless	AT&T	Sprint		
LTE	✓		✓		Band 2	Tx: 1850 – 1910 MHz Rx: 1930 – 1990 MHz
	✓	✓	✓		Band 4	Tx: 1710 – 1755 MHz Rx: 2110 – 2155 MHz
	✓		✓		Band 5	Tx: 824 – 849 MHz Rx: 869 – 894 MHz
	✓	✓			Band 13	Tx: 777 – 787 MHz Rx: 746 – 756 MHz
	✓		✓		Band 17	Tx: 704 – 716 MHz Rx: 734 – 746 MHz
	✓			✓	Band 25	Tx: 1850 – 1915 MHz Rx: 1930 – 1995 MHz
EV-DO	✓	✓		✓	BC0	Tx: 824 – 849 MHz Rx: 869 – 894 MHz
	✓	✓		✓	BC1	Tx: 1850 – 1910 MHz Rx: 1930 – 1990 MHz
	✓			✓	BC10	Tx: 817 – 824 MHz Rx: 861 – 869 MHz
HSPA	✓	✓	✓	✓	Band 1	Tx: 1920 – 1980 MHz Rx: 2110 – 2170 MHz
	✓	✓	✓	✓	Band 2	Tx: 1850 – 1910 MHz Rx: 1930 – 1990 MHz
	✓				Band 4	Tx: 1710 – 1755 MHz Rx: 2110 – 2155 MHz
	✓	✓	✓	✓	Band 5	Tx: 824 – 849 MHz Rx: 869 – 894 MHz
	✓	✓	✓	✓	Band 8	Tx: 880 – 915 MHz Rx: 925 – 960 MHz

Table 3-9: MP70E Radio Module MC7354 US (Continued)

Radio Technology	SKU				Band	Frequencies
	Generic	Verizon Wireless	AT&T	Sprint		
EDGE	✓	✓	✓	✓	GSM 850	Tx: 824–849 MHz Rx: 869–894 MHz
	✓	✓	✓	✓	GSM 900	Tx: 880–915 MHz Rx: 925–960 MHz
	✓	✓	✓	✓	DCS 1800	Tx: 1710–1785 MHz Rx: 1805–1880 MHz
	✓	✓	✓	✓	PCS 1900	Tx: 1850–1910 MHz Rx: 1930–1990 MHz

Table 3-10: Radio Module MC7354 Conducted Transmit Power

Band	Conducted Tx Power (dBm)	Notes
LTE		
Band 2 Band 4 Band 5 Band 13 Band 17 Band 25	+23±1	
UMTS		
Band 1 (IMT 2100 12.2 kbps) Band 2 (UMTS 1900 12.2 kbps) Band 4 (AWS 1700/2100 12.2 kbps) Band 5 (UMTS 850 12.2 kbps) Band 8 (UMTS 900 12.2 kbps)	+23±1	Connectorized (Class 3)
GSM / EDGE		
GSM 850 CS GSM 900 CS	+32±1	GMSK mode, connectorized (Class 4)
	+27±1	8 PSK mode, connectorized (Class E2)
DCS 1800 CS PCS 1900 CS	+29±1	GMSK mode, connectorized (Class 4)
	+26±1	8 PSK mode, connectorized (Class E2)

Table 3-10: Radio Module MC7354 Conducted Transmit Power (Continued)

Band	Conducted Tx Power (dBm)	Notes
CDMA		
Band Class 0 (Cellular)	+24+0.5/-1	
Band Class 1 (PCS)		
Band Class 10 (Cellular)		

Table 3-11: MP70 LTE-A Pro Radio Module EM7511 North America

Radio Technology	SKU			Band	Frequencies
	Generic	Verizon Wireless	AT&T		
LTE	✓		✓	Band 1	Tx: 1920–1980 MHz Rx: 2110–2170 MHz
	✓	✓	✓	Band 2	Tx: 1850–1910 MHz Rx: 1930–1990 MHz
	✓		✓	Band 3	Tx: 1710–1785 MHz Rx: 1805–1880 MHz
	✓	✓	✓	Band 4	Tx: 1710–1755 MHz Rx: 2110–2155 MHz
	✓	✓	✓	Band 5	Tx: 824–849 MHz Rx: 869–894 MHz
	✓		✓	Band 7	Tx: 2500–2570 MHz Rx: 2620–2690 MHz
	✓		✓	Band 8	Tx: 880–915 MHz Rx: 925–960 MHz
	✓		✓	Band 9	Tx: 1749.9–1784.9 MHz Rx: 1844.9–1879.9 MHz
	✓		✓	Band 12	Tx: 699–716 MHz Rx: 729–746 MHz
	✓	✓	✓	Band 13	Tx: 777–787 MHz Rx: 746–756 MHz
	✓		✓	Band 14	Tx: 788–798 MHz Rx: 758–768 MHz
	✓		✓	Band 18	Tx: 815–830 MHz Rx: 860–875 MHz
	✓		✓	Band 19	Tx: 830–845 MHz Rx: 875–890 MHz
	✓		✓	Band 20	Tx: 832–862 MHz Rx: 791–821 MHz
✓		✓	Band 26	Tx: 814–849 MHz Rx: 859–894 MHz	

Table 3-11: MP70 LTE-A Pro Radio Module EM7511 North America (Continued)

Radio Technology	SKU			Band	Frequencies
	Generic	Verizon Wireless	AT&T		
	✓		✓	Band 29	Tx: n/a Rx: 717 – 728 MHz
	✓			Band 30	Tx: n/a Rx: 2350 – 2360 MHz
	✓		✓	Band 32	Tx: n/a Rx: 1452 – 1496 MHz
	✓		✓	Band 41	2496 – 2690 MHz (TDD)
	✓		✓	Band 42	3400 – 3600 MHz (TDD)
	✓		✓	Band 43	3600 – 3800 MHz (TDD)
	✓		✓	Band 46	5150 – 5925 MHz (TDD)
	✓		✓	Band 48	3550 – 3700 MHz (TDD)
	✓	✓	✓	Band 66	Tx: 1710 – 1780 MHz Rx: 2110 – 2200 MHz
HSPA	✓	✓	✓	Band 1	Tx: 1920 – 1980 MHz Rx: 2110 – 2170 MHz
	✓	✓	✓	Band 2	Tx: 1850 – 1910 MHz Rx: 1930 – 1990 MHz
	✓	✓	✓	Band 4	Tx: 1710 – 1755 MHz Rx: 2110 – 2155 MHz
	✓	✓	✓	Band 5	Tx: 824 – 849 MHz Rx: 869 – 894 MHz
	✓	✓	✓	Band 6	Tx: 830 – 840 MHz Rx: 875 – 885 MHz
	✓	✓	✓	Band 8	Tx: 880 – 915 MHz Rx: 925 – 960 MHz
	✓	✓	✓	Band 9	Tx: 1749.9 – 1784.9 MHz Rx: 1844.9 – 1879.9 MHz
	✓	✓	✓	Band 19	Tx: 830 – 845 MHz Rx: 875 – 890 MHz

Table 3-12: Radio Module EM7511 Conducted Transmit Power

Band	Conducted Tx Power (dBm)	Notes
LTE		
Band 1 Band 2 Band 3 Band 4 Band 5 Band 8 Band 9 Band 12	Band 13 Band 14 Band 18 Band 19 Band 20 Band 26 Band 30 Band 66	+23±1
Band 7 Band 41	Band 42 Band 43	+22±1
Band 48		+19±1
UMTS		
Band 1 (IMT 2100 12.2 kbps) Band 2 (UMTS 1900 12.2 kbps) Band 4 (AWS 1700/2100 12.2 kbps) Band 5 (UMTS 850 12.2 kbps) Band 6 (UMTS 800 12.2 kbps) Band 8 (UMTS 900 12.2 kbps) Band 9 (UMTS 1700 12.2 kbps) Band 19 (UMTS 800 12.2 kbps)		+23±1 Connectorized (Class 3)

Table 3-13: MP70 LTE-A Pro Radio Module EM7565 Global

Radio Technology	Band	Frequencies	
LTE	Band 1	Tx: 1920 – 1980 MHz	Rx: 2110 – 2170 MHz
	Band 2	Tx: 1850 – 1910 MHz	Rx: 1930 – 1990 MHz
	Band 3	Tx: 1710 – 1785 MHz	Rx: 1805 – 1880 MHz
	Band 4	Tx: 1710 – 1755 MHz	Rx: 2110 – 2155 MHz
	Band 5	Tx: 824 – 849 MHz	Rx: 869 – 894 MHz
	Band 7	Tx: 2500 – 2570 MHz	Rx: 2620 – 2690 MHz
	Band 8	Tx: 880 – 915 MHz	Rx: 925 – 960 MHz
	Band 9	Tx: 1749.9 – 1784.9 MHz	Rx: 1844.9 – 1879.9 MHz
	Band 12	Tx: 699 – 716 MHz	Rx: 729 – 746 MHz
	Band 13	Tx: 777 – 787 MHz	Rx: 746 – 756 MHz
	Band 18	Tx: 815 – 830 MHz	Rx: 860 – 875 MHz
	Band 19	Tx: 830 – 845 MHz	Rx: 875 – 890 MHz
	Band 20	Tx: 832 – 862 MHz	Rx: 791 – 821 MHz
	Band 26	Tx: 814 – 849 MHz	Rx: 859 – 894 MHz
	Band 28	Tx: 703 – 748 MHz	Rx: 758 – 803 MHz
	Band 29	Tx: n/a	Rx: 717 – 728 MHz
	Band 30	Tx: n/a	Rx: 2350 – 2360 MHz
	Band 32	Tx: n/a	Rx: 1452 – 1496 MHz
	Band 41	2496 – 2690 MHz (TDD)	
	Band 42	3400 – 3600 MHz (TDD)	
Band 43	3600 – 3800 MHz (TDD)		
Band 46	5150 – 5925 MHz (TDD)		
Band 48	3550 – 3700 MHz (TDD)		
Band 66	Tx: 1710 – 1780 MHz	Rx: 2110 – 2200 MHz	

Table 3-13: MP70 LTE-A Pro Radio Module EM7565 Global (Continued)

Radio Technology	Band	Frequencies	
HSPA	Band 1	Tx: 1920 – 1980 MHz	Rx: 2110 – 2170 MHz
	Band 2	Tx: 1850 – 1910 MHz	Rx: 1930 – 1990 MHz
	Band 4	Tx: 1710 – 1755 MHz	Rx: 2110 – 2155 MHz
	Band 5	Tx: 824 – 849 MHz	Rx: 869 – 894 MHz
	Band 6	Tx: 830 – 840 MHz	Rx: 875 – 885 MHz
	Band 8	Tx: 880 – 915 MHz	Rx: 925 – 960 MHz
	Band 9	Tx: 1749.9 – 1784.9 MHz	Rx: 1844.9 – 1879.9 MHz
	Band 19	Tx: 830 – 845 MHz	Rx: 875 – 890 MHz

Table 3-14: Radio Module EM7565 Conducted Transmit Power

Band	Conducted Tx Power (dBm)	Notes
LTE		
Band 1 Band 13 Band 2 Band 18 Band 3 Band 19 Band 4 Band 20 Band 5 Band 26 Band 8 Band 28 Band 9 Band 66 Band 12	+23±1	
Band 7 Band 42 Band 41 Band 43	+22±1	
Band 48	+19±1	
UMTS		
Band 1 (IMT 2100 12.2 kbps) Band 2 (UMTS 1900 12.2 kbps) Band 4 (AWS 1700/2100 12.2 kbps) Band 5 (UMTS 850 12.2 kbps) Band 6 (UMTS 800 12.2 kbps) Band 8 (UMTS 900 12.2 kbps) Band 9 (UMTS 1700 12.2 kbps) Band 19 (UMTS 800 12.2 kbps)	+23±1	Connectorized (Class 3)

GNSS Bands supported

Table 3-15: GNSS Bands Supported

Band	Frequency
GPS	1575.42 MHz
GLONASS	1602 MHz
Galileo	1575.42 MHz
BeiDou	1561.098 MHz
QZSS	1176.45 – 1575.42 MHz

Carrier Aggregation Combinations

LTE-Advanced uses carrier aggregation to increase bandwidth. The following tables show the carrier aggregation combinations.

Table 3-16: MC7455 Carrier Aggregation Combinations

1 + 8
2 + 2/5/12/13/29
3 + 7/20
4 + 4/5/12/13/29
5 + 2/4
7 + 3/7/20
8 + 1
12 + 2/4
13 + 2/4
20 + 3/7
41 + 41

Table 3-17: MC7430 Carrier Aggregation Combinations

1 + 8/18/19/21
3 + 5/7/19/28
5 + 3/7
7 + 3/5/7/28
8 + 1
18 + 1

Table 3-17: MC7430 Carrier Aggregation Combinations (Continued)

19 + 1/3/21
21 + 1/19
28 + 3/7
38 + 38
39 + 39
40 + 40
41 + 41

Table 3-18: EM7511 PTCRB Carrier Aggregation Downlink Combinations^a

1 Band / 2CC	1 Band / 3CC	2 Bands / 2CC	2 Bands / 3CC	3 Bands / 3CC
		1A-3A	1A-7A-7A	1A-3A-5A
		1A-5A		1A-3A-7A
		1A-7A		1A-3A-8A
		1A-18A		1A-3A-19A
		1A-19A		1A-3A-20A
		1A-20A		1A-5A-7A
		1A-26A		1A-7A-20A
		1A-41A		
2A-2A		2A-4A	2A-2A-5A	2A-4A-5A
2C		2A-7A	2A-2A-12A	2A-4A-7A
		2A-12A	2A-2A-13A	2A-4A-12A
		2A-13A	2A-2A-14A	2A-4A-13A
		2A-14A	2A-7A-7A	2A-4A-29A
		2A-29A	2A-66A-66A	2A-12A-30A
		2A-30A	2A-66B	2A-13A-66A
		2A-46A	2A-66C	2A-14A-30A
		2A-66A		2A-14A-66A
				2A-29A-30A
3A-3A		3A-5A	3A-3A-7A	3A-7A-20A
3C		3A-7A	3C-5A	
		3A-8A	3A-7B	
		3A-19A	3A-7C	
		3A-20A	3A-7A-7A	

Table 3-18: EM7511 PTCRB Carrier Aggregation Downlink Combinations^a (Continued)

1 Band / 2CC	1 Band / 3CC	2 Bands / 2CC	2 Bands / 3CC	3 Bands / 3CC
		3A-41A	3C-7A	
			3C-20A	
			3A-41C	
4A-4A		4A-5A	4A-4A-5A	4A-5A-30A
		4A-7A	4A-4A-12A	4A-7A-12A
		4A-12A	4A-4A-13A	4A-12A-30A
		4A-13A	4A-4A-30A	4A-29A-30A
		4A-29A	4A-7A-7A	
		4A-30A		
		4A-46A		
5B		5A-7A	5A-66C	5A-30A-66A
		5A-30A		
		5A-66A	5A-66A-66A	
		5A-66B		
7B		7A-12A		
7C		7A-20A		
		12A-30A		12A-30A-66A
		12A-66A		
		13A-66A	13A-66A-66A	
		13A-66B		
		13A-66C		
		14A-30A	14A-66A-66A	14A-30A-66A
		14A-66A		
		20A-32A		
		29A-66A		29A-30A-66A
	41D			
66B	66A-66B			
66C	66A-66C			

a. Supported CA DL combinations outside of North America are carrier-dependent.

Table 3-19: EM7511 Additional Carrier Aggregation Downlink Combinations^a

1 Band / 2CC	1 Band / 3CC	2 Bands / 2CC	2 Bands / 3CC	3 Bands / 3CC
		1A-8A	1A-42C	
		1A-42A		
		2A-5A		2A-5A-30A
				2A-5A-66A
				2A-7A-12A
			3A-42C	3A-41A-42A
		3A-42A		
		5A-46A		
7A-7A				
		13A-46A		
		19A-42A	19A-42C	
41C		41A_42A	41A-42C	
		41C-42A		
42C				
48A-48A			48A-48C	
48C				
	48D			

a. Supported CA DL combinations outside of North America are carrier-dependent.

Table 3-20: EM7511 Carrier Aggregation Uplink Combinations

3C
7C
41C

Table 3-21: EM7565 PTCRB Carrier Aggregation Downlink Combinations^a

1 Band / 2CC	1 Band / 3CC	2 Bands / 2CC	2 Bands / 3CC	3 Bands / 3CC
		1A-3A	1A-7A-7A	1A-3A-5A
		1A-5A		1A-3A-7A
		1A-7A		1A-3A-8A
		1A-18A		1A-3A-19A

Table 3-21: EM7565 PTCRB Carrier Aggregation Downlink Combinations^a (Continued)

1 Band / 2CC	1 Band / 3CC	2 Bands / 2CC	2 Bands / 3CC	3 Bands / 3CC
		1A-19A		1A-3A-20A
		1A-20A		1A-5A-7A
		1A-26A		1A-7A-20A
		1A-41A		
2A-2A		2A-4A	2A-2A-5A	2A-4A-5A
2C		2A-7A	2A-2A-12A	2A-4A-7A
		2A-12A	2A-2A-13A	2A-4A-12A
		2A-13A	2A-7A-7A	2A-4A-13A
		2A-29A	2A-66A-66A	2A-4A-29A
		2A-30A	2A-66B	2A-12A-30A
		2A-46A	2A-66C	2A-13A-66A
		2A-66A		2A-29A-30A
3A-3A		3A-5A	3A-3A-7A	3A-7A-20A
3C		3A-7A	3C-5A	
		3A-8A	3A-7B	
		3A-19A	3A-7C	
		3A-20A	3A-7A-7A	
		3A-41A	3C-7A	
			3C-20A	
			3A-41C	
4A-4A		4A-5A	4A-4A-5A	4A-5A-30A
		4A-7A	4A-4A-12A	4A-7A-12A
		4A-12A	4A-4A-13A	4A-12A-30A
		4A-13A	4A-4A-30A	4A-29A-30A
		4A-29A	4A-7A-7A	
		4A-30A		
		4A-46A		
		5A-30A	5A-66C	5A-30A-66A
		5A-66A	5A-66A-66A	
7B		7A-12A		
7C		7A-20A		
		12A-30A		12A-30A-66A
		12A-66A		

Table 3-21: EM7565 PTCRB Carrier Aggregation Downlink Combinations^a (Continued)

1 Band / 2CC	1 Band / 3CC	2 Bands / 2CC	2 Bands / 3CC	3 Bands / 3CC
		13A-66A	13A-66A-66A	
		13A-66B		
		20A-32A		
		29A-66A		29A-30A-66A
	41D			
66B	66A-66B			
66C	66A-66C			

a. Supported CA DL combinations outside of North America are carrier-dependent.

Table 3-22: EM7565 Additional Carrier Aggregation Downlink Combinations^a

1 Band / 2CC	1 Band / 3CC	2 Bands / 2CC	2 Bands / 3CC	3 Bands / 3CC
		1A-8A	1A-42C	1A-3A-28A
		1A-42A		
		2A-5A		2A-5A-30A
		2A-28A		2A-5A-66A
				2A-7A-12A
		3A-28A	3A-42C	3A-41A-42A
		3A-42A		3A-7A-28A
		3C-28A		
		4A-28A		
5B		5A-7A		
		5A-46A		
		5A-66B		
7A-7A		7A-28A		
		7B-28A		
		7C-28A		
		13A-46A	13A-66C	
		19A-42A	19A-42C	
		28A-42A		
41C		41A_42A	41A-42C	
		41C-42A		
42C				

Table 3-22: EM7565 Additional Carrier Aggregation Downlink Combinations^a (Continued)

1 Band / 2CC	1 Band / 3CC	2 Bands / 2CC	2 Bands / 3CC	3 Bands / 3CC
48A-48A			48A-48C	
48C				
	48D			

a. Supported CA DL combinations outside of North America are carrier-dependent.

Table 3-23: EM7565 Carrier Aggregation Uplink Combinations

3C
7C
41C

Mechanical Specifications

- Housing — The MP70 is made of ruggedized powder-coated aluminum.
- RoHS2 — The MP70 complies with the Restriction of Hazardous Substances Directive 2011/65/EU (RoHS2). This directive restricts the use of hazardous materials in the manufacture of various types of electronic and electrical equipment.

Weight: 0.76 kg (1.68 lb.)

Back view

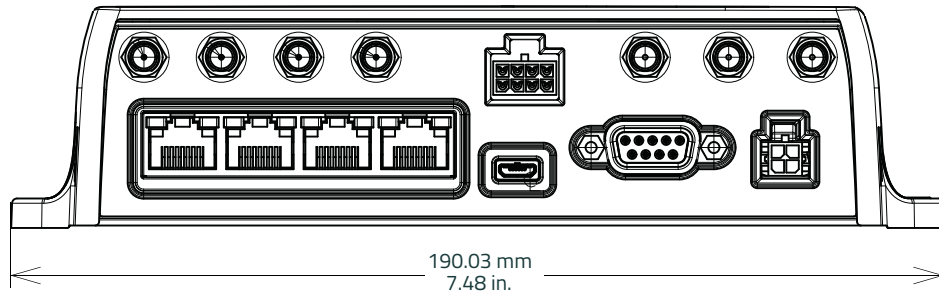

Front view

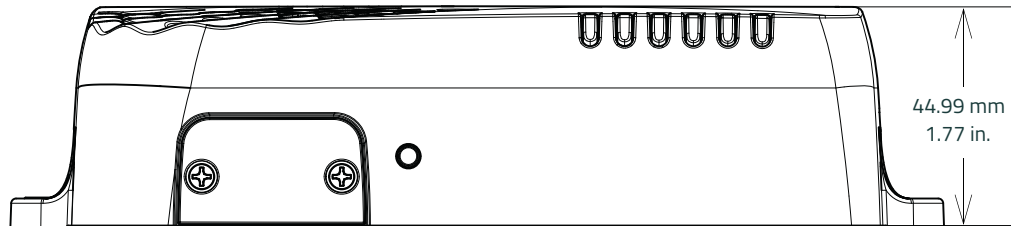

Underside view

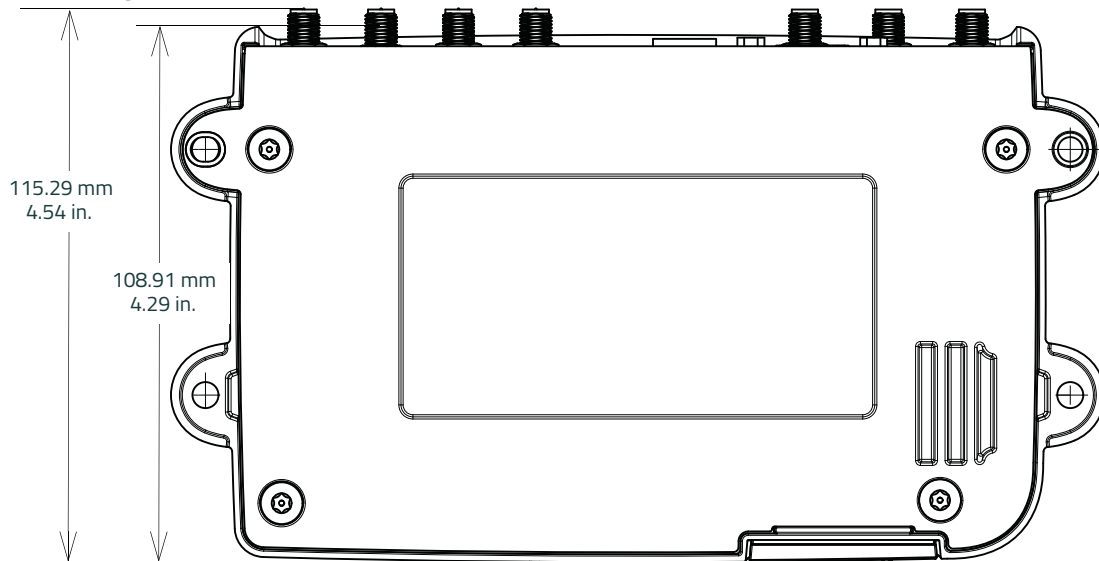

Figure 3-2: MP70 Mechanical Specifications

4: Regulatory Information

Important Information for North American Users

Note: This equipment has been tested and found to comply with the limits for a Class B digital device, pursuant to part 15 of the FCC Rules. These limits are designed to provide reasonable protection against harmful interference in a residential installation. This equipment generates, uses and can radiate radio frequency energy and, if not installed and used in accordance with the instructions, may cause harmful interference to radio communications. However, there is no guarantee that interference will not occur in a particular installation. If this equipment does cause harmful interference to radio or television reception, which can be determined by turning the equipment off and on, the user is encouraged to try to correct the interference by one or more of the following measures:

- *Reorient or relocate the receiving antenna.*
- *Increase the separation between the equipment and receiver.*
- *Connect the equipment into an outlet on a circuit different from that to which the receiver is connected.*
- *Consult the dealer or an experienced radio/TV technician for help.*

Warning: *Changes or modifications to this device not expressly approved by Sierra Wireless could void the user's authority to operate this equipment.*

RF Exposure

In accordance with FCC/IC requirements of human exposure to radio frequency fields, the radiating element shall be installed such that a minimum separation distance of 20 cm should be maintained from the antenna and the user's body.

Warning: *This product is only to be installed by qualified personnel.*

To comply with FCC/IC regulations limiting both maximum RF output power and human exposure to RF radiation, the maximum antenna gain must not exceed the specifications listed below for the device used.

Maximum Antenna Gain

The antenna gain must not exceed the limits and configurations shown in the following tables:

Table 4-1: MP70 Maximum Antenna Gain

Device	Frequency Band	FCC ID/IC Number N7NMC7455/2417C-MC7455 Maximum Antenna Gain (dBi)
AirLink MP70	2	6
	4	6
	5	6
	7	9
	12	6
	13	6
	25	6
	26	6
	41	9

Table 4-2: MP70E Maximum Antenna Gain

Device	Frequency Band	FCC ID N7NMC7354 Maximum Antenna Gain (dBi)
AirLink MP70E	2	3
	4	4
	5	4
	13	4
	17	4
	25	3

Table 4-3: MP70 LTE-A Pro Maximum Antenna Gain

Device	Frequency Band	FCC ID/IC Number N7NEM75S/2417C-EM75S Maximum Antenna Gain (dBi)
AirLink MP70 LTE-A Pro	2	4
	4	4
	5	4
	7	4
	12	4
	13	4
	14	4
	26	4
	30	1
	41	4
	66	4

EU

Sierra Wireless hereby declares the AirLink MP70 device is in compliance with the essential requirements and other relevant provisions of Directive 2014/53/EU.

The MP70 displays the CE mark.



Warning: Changes or modifications to this device not expressly approved by Sierra Wireless could void the user's authority to operate this equipment.

Warning: This product is only to be installed by qualified personnel.

Declaration of Conformity

The Declaration of Conformity made under Directive 2014/53/EU is available for viewing at:
source.sierrawireless.com/resources/airlink/certification_and_type_approval/MP70_ce_declaration_of_conformity/.

WEEE Notice



If you purchased your AirLink MP70 in Europe, please return it to your dealer or supplier at the end of its life. WEEE products may be recognized by their wheeled bin label on the product label.

A: Accessories

DC Power Cable (Black Connector)

Table A-1: DC Power Cable

DC Power Cable	
Part Number	2000522
Product Release	2016

Components:

- ❶ 1 UL2464 20 AWG × 4 core cable
- ❷ 4 Molex female crimp terminals /AWG 20-24, 250V, 4A Max, phosphor bronze tin-plated (part number 43030-0001)
- ❸ 1 Molex male 2×2P Ph: 3.0 mm housing, 250V, 5 A max, PA65 black UL94V-0 (part number 43025-0408)

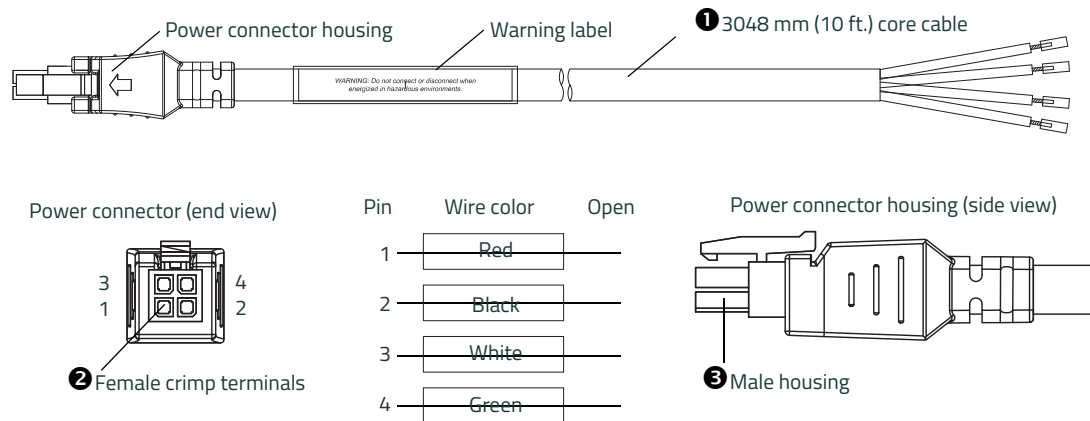

Figure A-1: DC Cable Specifications

AC Power Adapter (Black Connector)

Table A-2: AC Power Adapter

AC Power Adapter	
Part Number	2000579
Product Release	2016

AC Power Adapter Input

Table A-3: Input Specifications

	Minimum	Typical	Maximum
Input			
Input Voltage	90 VAC	100–240 VAC	264 VAC
Input Frequency	47 Hz	50/60 Hz	63 Hz
<p><i>Note: Input voltage range is 90 VAC to 264 VAC. Maximum input current is 500 mA at 100–240 VAC. Inrush current will not exceed 75 A at 100–240 VAC input and maximum load from a cold start at 25 °C.</i></p>			

AC Power Adapter Output

Table A-4: AC Power Adapter Output Specifications

	Minimum	Typical	Maximum	Test conditions
Output Voltage	11.4 VDC	12.0 VDC	12.6 VDC	0 ~ 1.5 A loading

AC Power Adapter Environmental Specifications

Table A-5: AC Power Adapter Environmental Specifications

Operating	
Operating Temperature	0°C ~ 40°C (operates normally)
Relative Humidity	10% ~ 90%
Altitude	Sea level to 2,000 meters
Vibration	1.0 mm, 10–55 Hz, 15 minutes per cycle for each axis (X, Y, Z)
Non-operating	
Storage Temperature	-30°C ~ 70°C
Relative Humidity	10% ~ 90%
Vibration and Shock	MIL-STD-810D, method 514

AC Power Adapter Reliability and Quality Control

AC Power Adapter MTBF

When the power supply is operating within the limits of this specification, the MTBF is at least 200,000 hours at 25°C (MIL-HDBK-217F).

Note: For router MTBF, see [Reliability](#) on page 34.

AC Power Adapter Safety Standards

The power supply is certified with the following international regulatory standards:

Table A-6: AC Power Adapter Safety standards

Regulatory Agency	Country or Region	Certified	Standard
UL	USA	Approved	UL60950-1
GS	Europe	Approved	EN60950-1
CE	Europe	Approved	EN60950-1
SAA	Australia	Approved	AS/NZS 60950
CCC	China	Approved	GB4943
CUL	Canada	Approved	CSA C22.2 NO.60950-1

AC Power Adapter EMC Standards

The power supply meets the radiated and conducted emission requirements for EN55022, FCC Part 15, Class B, GB9254.

AC Power Adapter Hazardous Substances

- EU Directive 2011/65/EU “RoHS”
- EU Directive 2012/19/EU “WEEE”
- REACH

AC Power Adapter Energy Efficiency

The AC adapter complies with International Efficiency Levels, as shown in [Table A-7](#).

Table A-7: AC Adapter Energy Efficiency

Supplied Input	No-load Power Consumption	Average Active Mode Efficiency	International Efficiency Level
115 VAC, 60 Hz	Less than 0.1 W	Greater than 85%	VI
230 VAC, 50 Hz	Less than 0.3 W	Greater than 80.4%	V

Vehicle Bus Cables

The vehicle bus interface cables are shielded and terminated, and designed for use with the MP70 Series only.

Table A-8: Vehicle Bus Cable Accessories

Part Number	Description	Length	Connector
6001204	MP70, OBD-II Y-cable	5 meters	OBD-II
6001192	MP70, J1939 Y-cable	5 meters	Deutsch 9-pin Type I/II

Table A-9: Vehicle Bus Cable Pin-outs

J1939 Pin	ODB-II Pin	MP70 Aux I/O Pin	Function
C	6	4	CAN-H
D	14	5	CAN-L
A	5	8	Ground

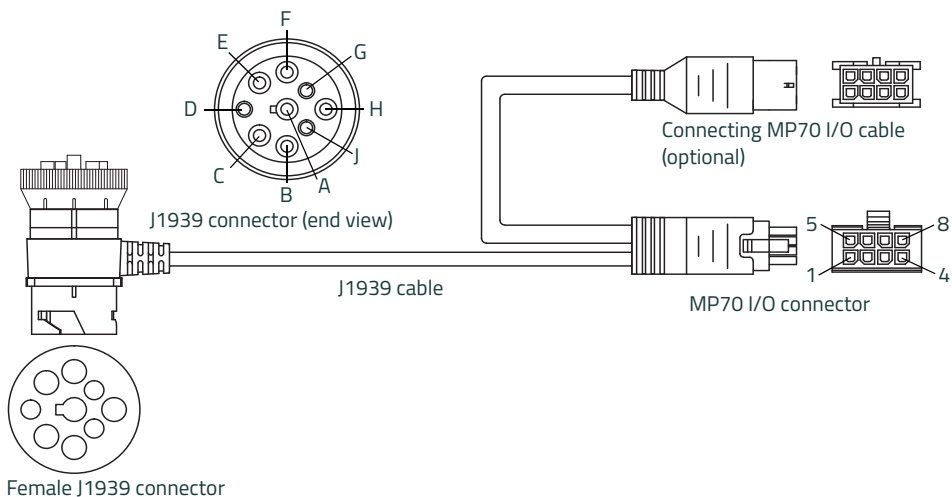
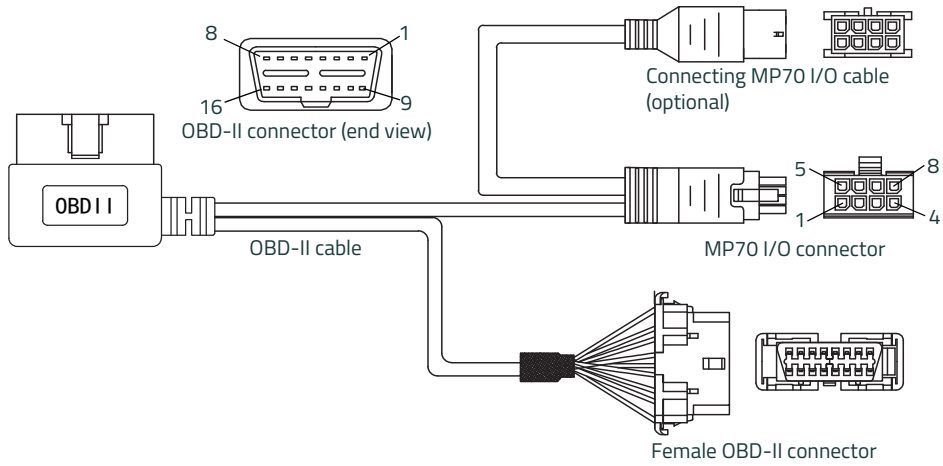

Figure A-2: Vehicle Bus Cables

I/O Cable

The AirLink auxiliary I/O cable is unshielded and terminated on one end, and designed for use with the AirLink MP70 Series, XR80/XR90, and LX60.

Table A-10: I/O Cable

Part Number	Description ^a	Length	Connector
6001004	XR/MP/LX I/O Cable	2 meters	8-pin Molex Micro-Fit connector

- a. The description used by vendors for this cable may indicate some combination of XR, MP, or LX model. However, these cables are intended for XR80/XR90, MP70, and LX60 routers.

Table A-11: I/O Cable Pin-out

I/O Cable Pin	Wire Color	Function	Notes
1	Black	Ground	Shorted to Pin 8 with 22AWG
2	Orange	IO4_IN	
3	Purple	IO3_IN	
4	Not connected		
5	Not connected		
6	Yellow	IO2_IN_A	
7	Gray	IO1_IN_A	
8	Black (22AWG)	Ground	Shorted to Pin 1 with 22AWG

- ❶ 1 UL2464 20AWGx5C unshielded, PVC black cable. Outer diameter 5.80 mm
- ❷
 - 5 Molex Micro-Fit 3.0 female crimp terminals: AWG 20-24, 600V, HSM copper tin-plated (part number 430300001)
 - 1 Molex Micro-Fit 3.0 female crimp terminal: AWG 18, 600V, HSM copper tin-plated (part number 458070003)
- ❸ 1 Molex male 8 circuit Micro-Fit 3.0 receptacle housing (part number 430250800)

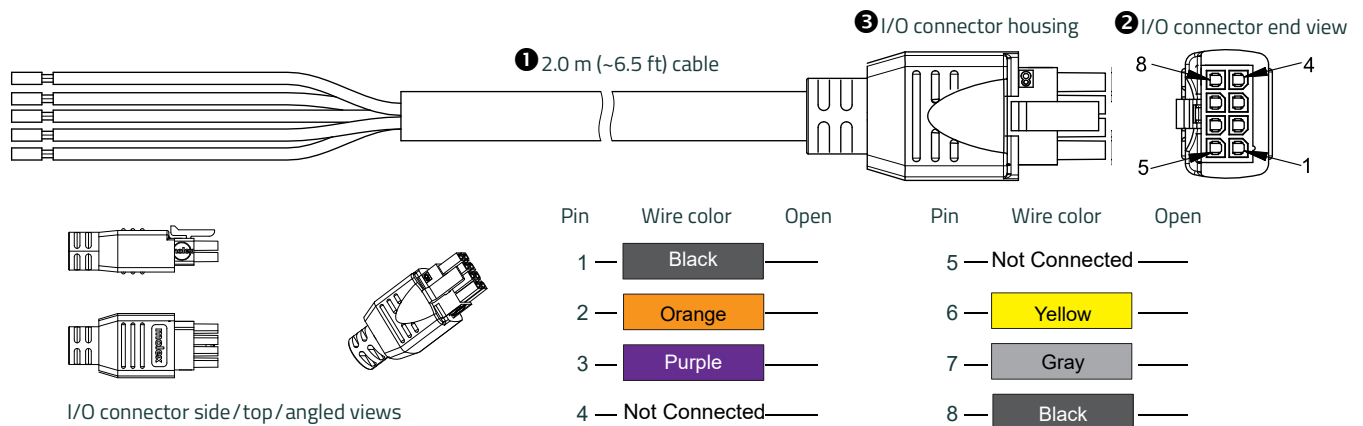

Figure A-3: IO Cable Specifications

Index

A

- AC power adapter, specifications, [70](#)
- Accessories, [10](#)
- ACEmanager, [31](#)
- AirLink Management Service, [31](#)
- ALEOS software, [30](#)
- AMM, [31](#)
- Analog input, [26](#)
- Antenna
 - Connecting, [14](#)
 - Gain, [66](#)
 - Maximum gain, [66](#)
 - Recommended separation, [15](#)
- AT commands, [32](#)

C

- Cable strain relief, [14](#)
- Cables, connecting, [15](#)
- Calibration, dead reckoning, [21](#)
- Carrier aggregation, [57](#)
- Certification
 - Mobile Network Operator, [36](#)
- Communication
 - AT commands, using, [32](#)
 - Command line prompt, using, [28](#)
- Configuring the router
 - AirLink Management Service, [31](#)
 - AT commands, [32](#)
- Current sink, [27](#)

D

- DC power cable
 - Specifications, [69](#)
 - Wires, [17](#)
- DC voltage transients, [16](#)
- Dead reckoning calibration, [21](#)
- Declaration of Conformity, [67](#)
- Digital I/O specifications, [40](#)
- Digital input, [24](#)
- Digital output, [28](#)
- Digital output/open drain, [28](#)

E

- Ethernet, LEDs, [30](#)
- EU, [67](#)

F

- Features, [8](#)
- Fusing, [16](#)

G

- GNSS, [40](#)
- GNSS, bands supported, [57](#)

- Grounding the chassis, [13](#)

H

- High side pull-up/dry contact switch input, [25](#)
- Host Interfaces, [37](#)

I

- I / O Configuration, [21](#)
- I/O auxiliary connector, [22](#)
- I/O pins, [22](#)
- Input
 - Analog, [26](#)
 - Dry contact switch, [25](#)
 - Ignition switch, [24](#)
- Installation
 - Connect data cables, [15](#)
 - Connect power cable, [16](#)
 - Connect vehicle bus cable, [20](#)
 - Connecting antennas, [14](#)
 - Fixed (with I/O), [20](#)
 - Fixed (without I/O), [19](#)
 - Insert SIM cards, [12](#)
 - Overview, [11](#)
 - Tools and materials required, [11](#)
 - Vehicle, [18](#)
- IP address, obtaining with command line prompt, [28](#)

L

- LED
 - Description of LED, [28](#)
 - Ethernet, [30](#)
- Low side current sink output, [27](#)
- LTE, bands supported, [36](#)

M

- MIMO, [14](#)
- MTBF
 - AC adapter, [71](#)
 - Router, [34](#)

O

- Open drain, [28](#)
- Operating voltage, [39](#)
- Output, digital, [28](#)

P

- Pinging the router with command line prompt, [28](#)

Power

- Connecting, [16](#)
- Connector, [16](#)
- Consumption, [10](#)
- input specifications, [40](#)
- Modes, [10](#)
- power supply specifications, [40](#)

Protocols, [40](#)

Pull-up resistor, [25](#)

Pulse counter, [24](#)

R

Rebooting, [32](#)

Recovery mode, [32](#)

Regulatory information, [65](#)

Regulatory specifications, [72](#)

Reliability, [34](#)

Reset to factory default settings, [32](#)

RF exposure, [65](#)

RF specifications, [14](#)

S

Screw Torque, [39](#)

Serial connector pin-out, [38](#)

Serial port, [38](#)

SIM cards, insert, [12](#)

Software, configure, [30](#)

Specifications, [34](#)

- Environmental, [34](#)

- GNSS, [40](#)

- Input / Output, [39](#)

- Regulatory, [72](#)

- RF, [14](#)

Standards, regulatory, [72](#)

T

Tools required for install, [11](#)

V

Voltage, input and ripple range, [40](#)

W

Warranty, [10](#)

WEEE, [68](#)

Wiring diagrams, [18](#)