

# TGPS-W9082GF-MM-M12X-QS-MV-IP54



ORing WEB-site

➤ **EN50155 10-port managed Gigabit PoE Ethernet switch with 8x10/100/1000Base-T(X) P.S.E. with X-coded M12 connector and 2x1000Base-SX, multi-mode, 550m/850nm, Q-ODC connector, IP-54 grade**

## Features

- Leading EN50155-compliant Ethernet switch for rolling stock application
- Support 2 Gigabit fiber ports with embedded Q-ODC interface
- Support O-Ring (recovery time < 30ms over 250 units of connection) and MSTP (RSTP/STP compatible) for Ethernet Redundancy
- O-Chain allow multiple redundant network rings
- Support standard IEC 62439-2 MRP<sup>\*NOTE</sup> (Media Redundancy Protocol) function
- Supports IEEE 802.3at compliant PoE and total power budget is 95 Watts with maximum 30Watts per port
- Support PoE scheduled configuration and PoE auto-ping check function
- Support IEEE 1588v2 clock synchronization
- Support IPV6 new internet protocol version
- Support Modbus TCP protocol
- Support IEEE 802.3az Energy-Efficient Ethernet technology
- Provided HTTPS/SSH protocol to enhance network security
- Support IP-based bandwidth management
- Support application-based QoS management
- Support Device Binding security function
- Support DOS/DDOS auto prevention
- IGMP v2/v3 (IGMP snooping support) for filtering multicast traffic
- Support SNMP v1/v2c/v3 & RMON & 802.1Q VLAN Network Management
- Support ACL, TACACS+ and 802.1x User Authentication for security
- Supports 9.6K Bytes Jumbo Frame
- Multiple notification for warning of unexpected event
- Web-based, Telnet, Console (CLI), and Windows utility (Open-Vision) configuration
- Support LLDP Protocol
- Wall mounting enabled
- IP-54 housing design



\*NOTE: This function is available by request only

## Introduction

ORing's Transporter™ series managed Ethernet switches are designed for industrial applications such as rolling stock, vehicle, and railway. The TGPS-W9082GF-MM-M12X-QS-MV-IP54, which is compliant with the EN50155 standard, is a managed Gigabit Redundant Ring Ethernet switch with 8x10/100/1000Base-T(X) P.S.E. and 2x1000Base-SX Q-ODC ports which is specifically designed for the toughest and fully compliant with EN50155 requirement. The switch support Ethernet Redundancy protocol, O-Ring (recovery time < 30ms over 250 units of connection), O-Chain, MRP<sup>\*NOTE</sup> and MSTP (RSTP/STP compatible) can protect your mission-critical applications from network interruptions or temporary malfunctions with its fast recovery technology. It is specifically designed for the toughest industrial environments. TGPS-W9082GF-MM-M12X-QS-MV-IP54 EN50155 Ethernet switch uses M12 connectors to ensure tight, robust connections, and guarantee reliable operation against environmental disturbances, such as vibration and shock. TGPS-W9082GF-MM-M12X-QS-MV-IP54 also support Power over Ethernet, a system to transmit electrical power up to 30 watts, along with data, to remote devices over standard twisted-pair cable in an Ethernet network. Each TGPS-W9082GF-MM-M12X-QS-MV-IP54 switch has 8x10/100/1000Base-T(X) P.S.E. (Power Sourcing Equipment) ports. P.S.E. is a device (switch or hub for instance) that will provide power in a PoE connection. While TGPS-W9082GF-MM-M12X-QS-MV-IP54 complies with EN50155, the switch supports wide operating temperature from -40°C to 75°C. TGPS-W9082GF-MM-M12X-QS-MV-IP54 can also be managed centralized and convenient by Open-Vision, Except the Web-based interface, Telnet and console (CLI) configuration. Therefore, the switch is one of the most reliable choice for highly-managed and Ethernet application.

- O-Ring:** O-Ring is ORing's proprietary redundant ring technology, with recovery time of less 30 milliseconds and up to 250 nodes. The O-Ring redundant ring technology can protect mission-critical application from network interruptions or temporary malfunction with its fast recover technology.
- O-Chain:** O-Chain is the revolutionary network redundancy technology that provides the add-on network redundancy topology for any backbone network, O-Chain allows multiple redundant network rings of different redundancy protocols to join and function together as a larger and more robust compound network topology. O-Chain providing ease-of-use while maximizing fault-recovery swiftness, flexibility, compatibility, and cost-effectiveness in one set of network redundancy topology.
- MRP: Media Redundancy Protocol (MRP)** <sup>\*NOTE</sup> is a data network protocol standardized by the IEC 62439-2. It allows rings of Ethernet switches to overcome any single failure with recovery time much faster than achievable with Spanning Tree Protocol.
- IP-based Bandwidth Management:** The switch provides advanced IP-based bandwidth management which can limit the maximum bandwidth for each IP device. User can configure IP camera and NVR with more bandwidth and limit other device bandwidth.
- Application-Based QoS:** The switch also supports application-based QoS. Application-based QoS can set highest priority for data stream according to TCP/UDP port number.
- Device Binding Function:** ORing special Device Binding function can only permit allowed IP address with MAC address to access the network. Hacker cannot access the IP surveillance network without permission. It can avoid hacker from stealing video privacy data and attacking IP camera, NVR and controllers.
- Advanced DOS/DDOS Auto Prevention:** The switch also provided advanced DOS/DDOS auto prevention. If there is any IP flow become big in short time, the switch will lock the source IP address for certain time to prevent the attack. It's hardware-based prevention so it can prevent DOS/DDOS attack immediately and completely.
- IEEE 1588v2 Technology:** The IEEE 1588v2 technology can fulfill precision time synchronization requirements for protection and control applications.
- Modbus TCP:** This is a Modbus variant used for communications over TCP/IP networks.
- IEEE 802.3az Energy-Efficient Ethernet:** This is a set of enhancements to the twisted-pair and backplane Ethernet family of networking standards that will allow for less power consumption during periods of low data activity. The intention was to reduce power consumption by 50% or more.

**\*NOTE: This function is available by request only**

## Open-Vision

ORing's switches are intelligent switches. Different from other traditional redundant switches, ORing provides a set of Windows Utility (Open-Vision) for user to manage and monitor all of industrial Ethernet switches on the industrial network.

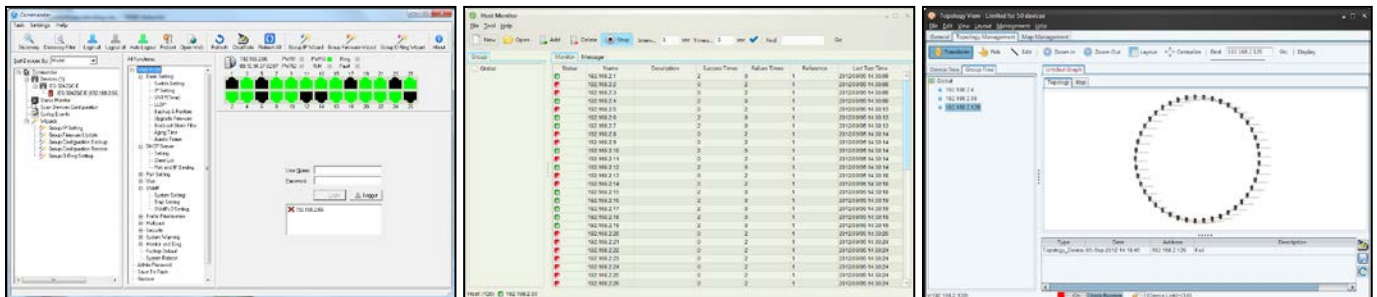

Commander

Host Monitor

Topology View





## Open-Vision 4.0

### Powerful Network Management Windows Utility

- Multi-link topology
- Centralized management view
- Traffic monitoring

## Dimensions

Unit=mm (Tolerance±0.5mm)

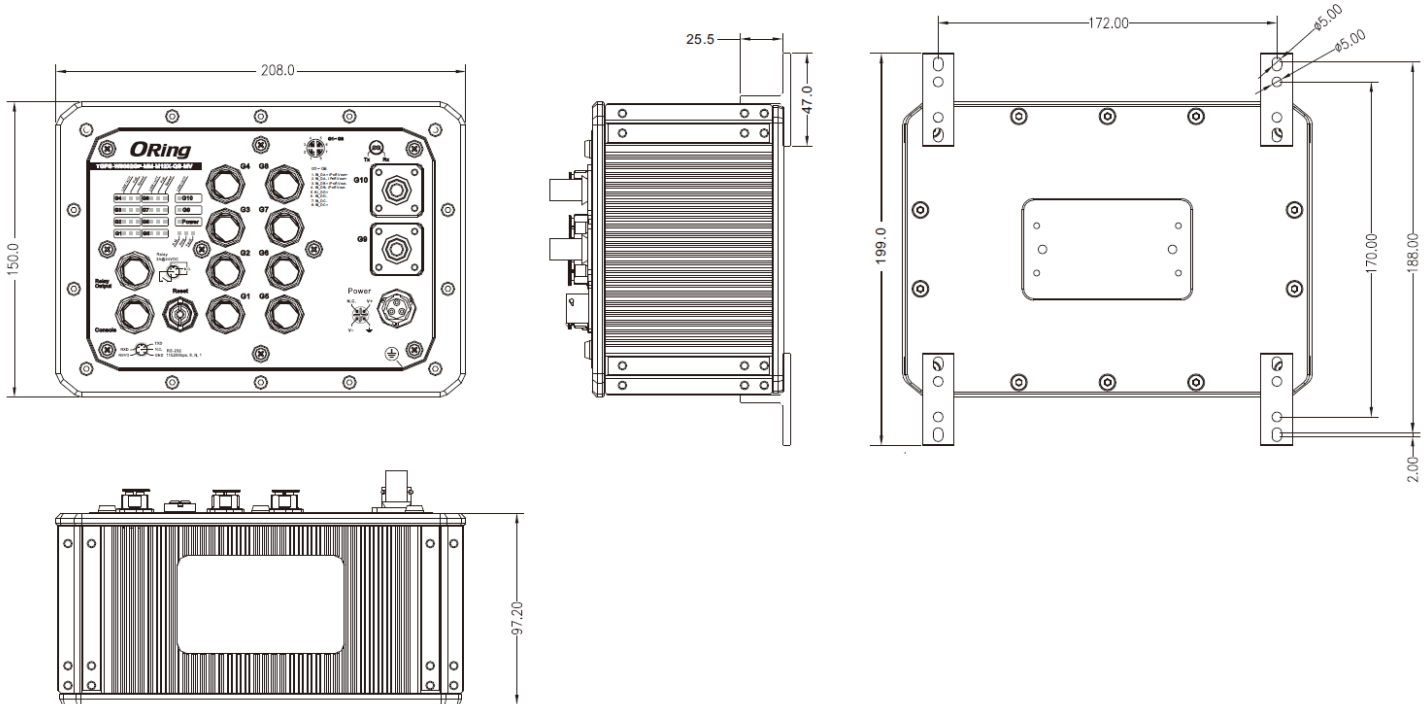

## Pin Definition

X-Coding M12		10/100/1000Base-T(X) P.S.E. M12 port	
Pin No.	Description	Pin No.	Description
1	BI_DA+ with PoE Vout+	#1	BI_DA+ with PoE Vout+
2	BI_DA- with PoE Vout+	#2	BI_DA- with PoE Vout+
3	BI_DB+ with PoE Vout-	#3	BI_DB+ with PoE Vout-
4	BI_DB- with PoE Vout-	#4	BI_DB- with PoE Vout-
5	BI_DD+	#5	BI_DD+
6	BI_DD-	#6	BI_DD-
7	BI_DC-	#7	BI_DC-
8	BI_DC+	#8	BI_DC+

## Specifications

ORing Switch Model	TGPS-W9082GF-MM-M12X-QS-MV-IP54
Physical Ports	
10/100/1000Base-T(X) with P.S.E. Ports in M12 Auto MDI/MDIX	8 (8-pin female X-coding)
1000Base-X Fiber Ports in Q-ODC connector	2 x Q-ODC connector (Multi-mode)

Fiber Ports Specifications	Fiber Ports Number	2
	Fiber Ports Standard	1000BASE-SX
	Fiber Mode	Multi-mode
	Fiber Diameter (µm)	62.5/125 µm @ 50/125 µm
	Fiber Optical Connector	Q-ODC
	Typical Distance (km)	0.55 Km
	Wavelength (nm)	850 nm
	Max. Output Optical Power (dBm)	-4 dbm
	Min. Output Optical Power (dBm)	-9.5 dbm
	Max. Input Optical Power (Saturation)	0 dbm
	Min. Input Optical Power (Saturation)	-18 dbm
	Link Budget (dB)	8.5 db
<b>Technology</b>		
Ethernet Standards	IEEE 802.3 for 10Base-T IEEE 802.3u for 100Base-TX IEEE 802.3z for 1000Base-X IEEE 802.3ab for 1000Base-T IEEE 802.3x for Flow control IEEE 802.3ad for LACP (Link Aggregation Control Protocol) IEEE 802.1p for COS (Class of Service) IEEE 802.1Q for VLAN Tagging IEEE 802.1w for RSTP (Rapid Spanning Tree Protocol) IEEE 802.1s for MSTP (Multiple Spanning Tree Protocol) IEEE 802.1x for Authentication IEEE 802.1AB for LLDP (Link Layer Discovery Protocol) IEEE 802.3at PoE specification (up to 30 Watts per port for P.S.E.) IEEE 802.3af PoE specification (up to 15.4 Watts per port for P.S.E.)	
MAC Table	8k	
Packet buffer Size	4Mbits	
Priority Queues	8	
Processing	Store-and-Forward	
Switch Properties	Switching latency: <4.7 µs Switching bandwidth: 20Gbps Throughput (packet per second): 17.856Mpps@64Bytes packet Max. Number of Available VLANs: 4095 IGMP multicast groups: 128 for each VLAN Port rate limiting: User Define	
Jumbo frame	Up to 9.6K Bytes	
Security Features	Device Binding security feature Enable/disable ports, MAC based port security Port based network access control (802.1x) VLAN (802.1Q) to segregate and secure network traffic Radius centralized password management SNMPv3 encrypted authentication and access security Https / SSH enhance network security	
Software Features	STP/RSTP/MSTP (IEEE 802.1D/w/s) Redundant Ring (O-Ring) with recovery time less than 30ms over 250 units TOS/Diffserv supported Quality of Service (802.1p) for real-time traffic VLAN (802.1Q) with VLAN tagging and GVRP supported IGMP Snooping IP-based bandwidth management Application-based QoS management DOS/DDOS auto prevention Port configuration, status, statistics, monitoring, security	

	DHCP Server/Client/Relay SMTP Client Modbus TCP
Network Redundancy	O-Ring O-Chain MRP <sup>*NOTE</sup> MSTP (RSTP/STP compatible)
RS-232 Serial Console Port	RS-232 in M12 connector (female A-coding). Baud rate setting: 115200bps, 8, N, 1
<b>LED indicators</b>	
Power Indicator (Power)	Green: Power LED x 1
Ring Master Indicator (R.M.)	Green: Indicates that the system is operating in O-Ring Master mode
O-Ring Indicator (Ring)	Green: Indicates that the system operating in O-Ring mode Green Blinking: Indicates that the Ring is broken.
Fault Indicator (Fault)	Red: Indicate unexpected event occurred
10/100/1000Base-T(X) M12 P.S.E. Port Indicator	Left Green LED for port Link/Act indicator: On for link-up, Off for link-down, Blinking for act. Middle Green LED for PoE enable indicator: On for PoE enabled, Off for PoE disabled. Right Dual color LED for Ethernet speed indicator: Green LED for 1000Mbps, Amber for 100Mbps, Off for 10Mbps
1000Base-SX Q-ODC Port Indicator	Green LED for Link/Act indicator: On for link-up, Off for link-down, Blinking for act.
<b>Fault contact</b>	
Relay	Relay output to carry capacity of 3A at 24VDC on M12 connector (5-pin A-coding, female connector)
<b>Reset Function</b>	
Reset Button	< 5 sec: System reboot, > 5 sec: Factory default
<b>Power</b>	
Input power	72/110 (50.4-137.5) VDC on 4-pin M12 S-coding, male connector
Power consumption (Typ.)	17 Watts (PoE output not include)
Total PoE Output Power	95 watts Max.
Overload current protection	Present
Reverse Polarity Protection	Present
<b>Physical Characteristic</b>	
Enclosure	IP-54
Dimension (W x D x H)	208 (W) x 89 (D) x 150 (H) mm 8.19 (W) x 3.5 (D) x 5.9 (H) inch
Weight (g)	3300 g
<b>Environmental</b>	
Storage Temperature	-40 to 85°C (-40 to 185°F)
Operating Temperature	-40 to 75°C (-40 to 167°F)
Operating Humidity	5% to 95% Non-condensing
<b>Regulatory approvals</b>	
EMC	CE EMC (EN 55024, EN 55032), FCC Part 15 B, EN 50155(EN 50121-1, EN 50121-3-2)
EMI	EN 55032, CISPR32, EN 61000-3-2, EN 61000-3-3, FCC Part 15 B class A
EMS	EN 55024 (IEC/EN 61000-4-2 (ESD: Contact 8KV, Air 10KV), IEC/EN 61000-4-3 (RS 80MHz to 1GHz: 3V/m 1kHz 80% AM), IEC/EN 61000-4-4 (EFT Power 2KV, Signal 2KV), IEC/EN 61000-4-5 (Surge: Power 4KV, RJ45 2KV), IEC/EN 61000-4-6 (CS 150K-80MHz: 3Vrms 1kHz 80% AM), IEC/EN 61000-4-8(PFMF), IEC/EN 61000-4-11 (DIP))
Shock	IEC60068-2-27
Free Fall	IEC60068-2-31
Vibration	IEC60068-2-6
Safety	EN 60950-1
Other	EN 50155 (IEC 61373)

\*NOTE: This function is available by request only

MTBF	258060 hrs.
Warranty	5 years

## Ordering Information

**TGPS-W9AA B CC-MM-M12X-QS-MV-IP54**

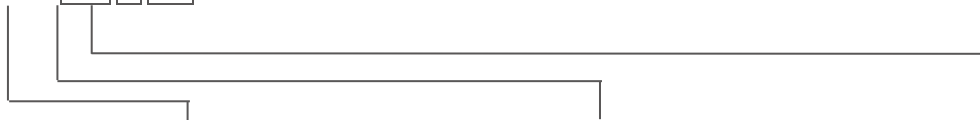

Code Definition	10/100/1000Base-T(X) P.S.E. Port Number	Additional Port Number	Additional Port Type
<b>Option</b>	<b>-08:</b> 8 ports	<b>-2:</b> 2 ports	<b>-GF:</b> 1000Base-X Fiber ports

Available Model	Model Name	Description
	TGPS-W9082GF-MM-M12X-QS-MV-IP54	EN50155 10-port managed Gigabit PoE Ethernet switch with 8x10/100/1000Base-T(X) P.S.E. with X-coded M12 connector and 2x1000Base-SX, multi-mode, 550m/850nm, Q-ODC connector, 110VDC Power Input, IP-54 grade
<b>Packing List</b>	<ul style="list-style-type: none"> <li>TGPS-W9082GF-MM-M12X-QS-MV-IP54x 1</li> <li>Quick Installation Guide x 1</li> <li>CD Card x 1</li> </ul>	<b>Optional Accessories</b> <ul style="list-style-type: none"> <li>Open-Vision M500: Powerful Network Management Windows Utility Suit, 500 IP devices</li> <li>SDR/NDR Series DIN-Rail power supply</li> <li>M12 cable series</li> </ul>